

# Commutation and Incremental Magnetic Encoder Solutions

EASY  
INSTALLATION

HIGH  
RESOLUTION

NON-  
CONTACT

**OnAxis™ commutation magnetic rotary encoder range is designed for use in BLDC motor feedback applications requiring both A, B, Z incremental and U, V, W commutation signals. To simplify alignment to the motor rotor, the encoder allows setting of the zero position. Robust non-contact OnAxis sensor technology provides ultimate long term reliability and performance.**

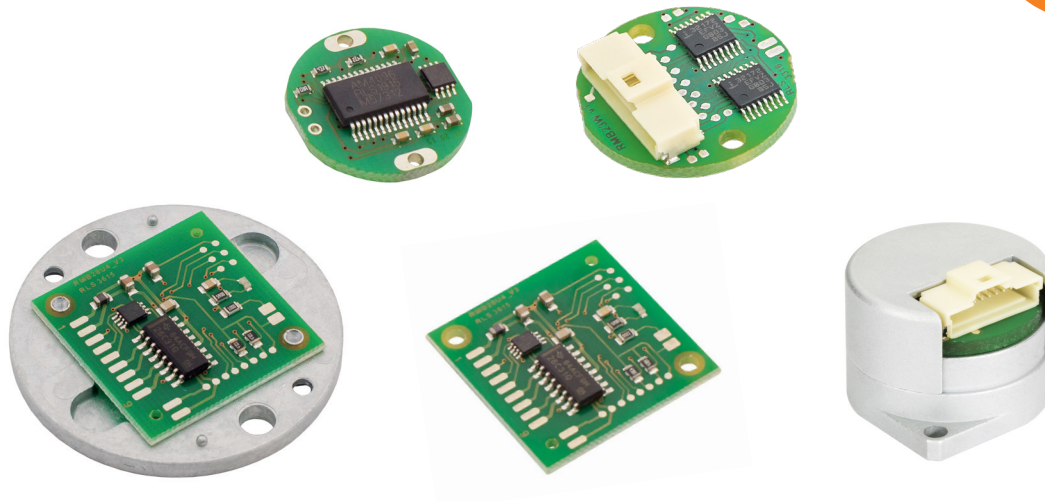

## Features and benefits

- ▶ Robust non-contact OnAxis encoders
- ▶ Resolutions from 256 to 16.384 counts per revolution
- ▶ U, V, W commutation signals up to 64 poles
- ▶ Encoder module sizes from 20 mm diameter to 58 mm diameter
- ▶ Operate in tough environments



MOTOR CONTROL



PRINTING



MARINE



MEDICAL



INDUSTRIAL AUTOMATION

## General information

Installation is simplified with a range of magnetic actuators and mounting options for the encoder. Resolutions are available from 64 to 4,096 pulses per revolution (256 to 16,384 counts per revolution with  $\times 4$  evaluation). U,V,W commutation signals are simultaneously output with 1 to 32 pole pairs (2 to 64 poles). Commutation encoders are available in different design variants and sizes, from 20 mm diameter encoder module RMB20 to 58 mm diameter encoder module on a metal flange RMF58 or as RMC22 and RMC35 on a metal flange with a removable metal cap to allow easy installation and zeroing.

## Product range

Product	Type	Dimensions	Available outputs	Commutation outputs	Incremental outputs	Power supply	Maximum speed
RMB29	Board	29 mm $\times$ 29 mm	Ex	U, V, W	-	5 V $\pm$ 10 %	30,000 rpm
RMB20		$\varnothing$ 20 mm	Ux				
RMB23		$\varnothing$ 23 mm	Wx	U, V, W and U+, U-, V+, V-, W+ W-			
RMB28		28 mm $\times$ 28 mm	Ux, Wx				
RMF44	Module on metal flange	$\varnothing$ 44 mm		Ux, Wx	U, V, W and U+, U-, V+, V-, W+ W-		
RMF58		$\varnothing$ 58 mm					
RM44	Enclosed encoder	$\varnothing$ 44 mm	Ux, Wx	U, V, W and U+, U-, V+, V-, W+ W-			
RM58		$\varnothing$ 58 mm					
RMC22	Module on metal flange with a removable metal cap	$\varnothing$ 22 mm	Ux	U, V, W			
RMC35		$\varnothing$ 35 mm					

# Storage and handling

## Operating and storage temperature



RMB, RMF, RMC: -40 °C to +105 °C (with connector)  
 RMB, RMF, RMC: -40 °C to +125 °C (without connector)  
 RM: -40 °C to 85 °C (IP68)  
 RM: -40 °C to +125 °C (IP64)

## Humidity



RMB and RMF: Up to 70 % non-condensing  
 RMC: Up to IP40  
 RM: Up to IP68

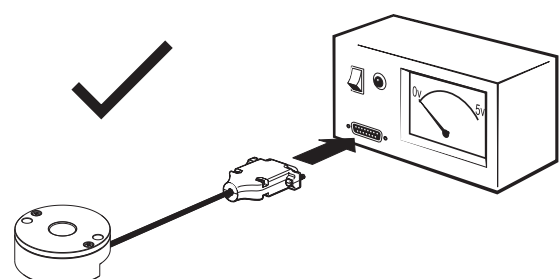
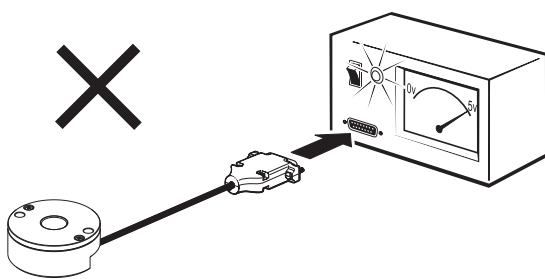
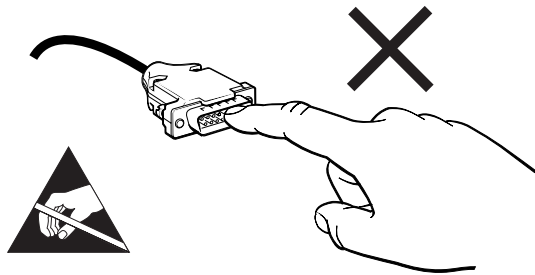

**Readhead is ESD sensitive - handle with care.**

Do not touch electronic circuit, wires or sensor area without proper ESD protection or outside of ESD controlled environment.

# Output types

## Incremental outputs

There are three signals for the incremental output: A, B and Z. Signals A and B are quadrature signals, shifted by 90°, and signal Z is a reference mark. The reference mark signal is produced once per revolution. The width of the Z pulse is 1/4 of the quadrature signal period and it is synchronized with the A and B signals. The chart below shows the timing diagram of A, B and Z signals with clockwise (CW) rotation of the magnet and positive counting direction. B leads A for CW rotation.

### Timing diagram - Incremental

Complementary signals not shown

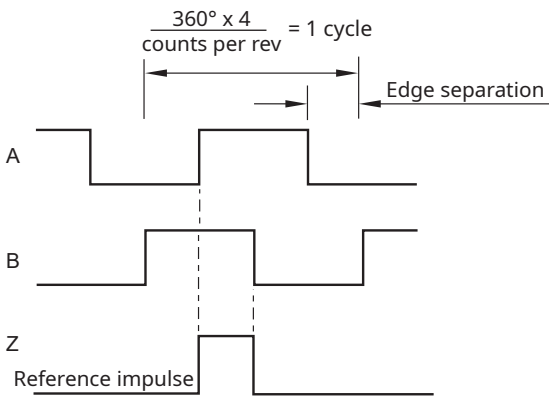

B leads A for clockwise rotation of magnetic actuator.

## Commutation outputs

UVW outputs can be output as digital signals. The number of signal periods (P) equals number of pole pairs. The timing diagram shows the signals when the position data is increasing. The U signal always starts at zero position regardless the signal period length (not valid for board B).

### Timing diagram - Commutation

Complementary signals not shown

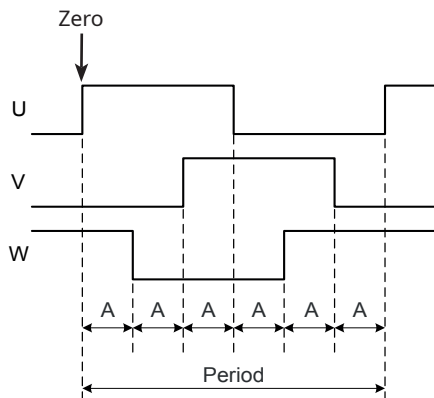

### Recommended signal termination - for complementary signals only

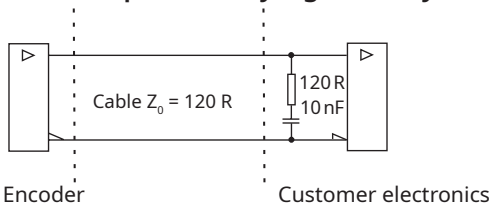

### UVW outputs

Board	Pole	A	Period	Pole pairs*
A	2	60°	360°	1
	4	30°	180°	2
	6	20°	120°	3
	8	15°	90°	4
	10	12°	72°	5
	12	10°	60°	6
	14	8.57°	51.42°	7
	16	7.50°	45°	8
	18	6.67°	40°	9
	20	6°	36°	10
B	22	5.45°	32.73°	11
	24	5°	30°	12
	26	4.62°	27.7°	13
	⋮			
	64	1.875°	11.25°	32

\* Number of pole pairs equals number of periods per revolution.

## RMB29Ex

### Connections

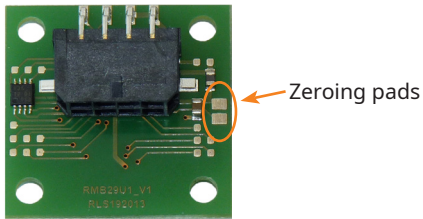

#### Connector on board

Molex 43045-0810

**Mating connector** (Not provided)

**Shell:** Molex 43025-0800

**8 pin crimp:** Molex 43030-0010

With pads or with Molex connector:

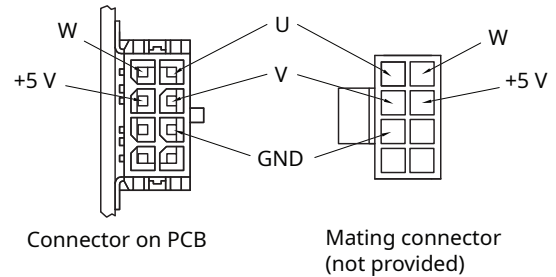

Product without connector is not conformal coated (polyurethane).

### Specifications

<b>Power supply</b>	$V_{dd} = 5\text{ V} \pm 10\%$
<b>Current consumption</b>	30 mA (not loaded)
<b>Maximum speed</b>	30,000 rpm
<b>Accuracy</b>	Typ. $\pm 0.5^\circ$
<b>Commutation outputs</b>	U, V, W
<b>Number of poles for commutation outputs</b>	2, 4, 6, 8, 10, 12, 14, 16
<b>Temperature</b>	-40 °C to +105 °C with connector
Operating and storage	-40 °C to +125 °C without connector

For dimensions and installation tolerances please refer to document RMB29D01 in [RLS Media center](#).

## RMB20Ux

### Connections

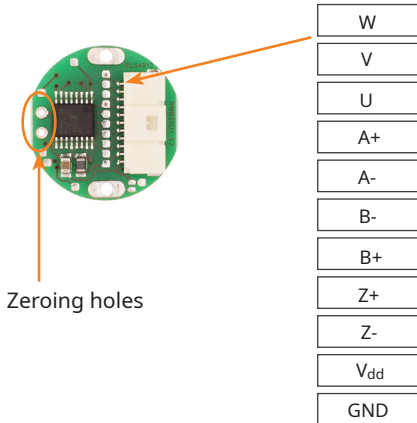

**Connector on board**

Molex 501568-1107

**Mating connector** (Not provided)

**Shell:** Molex 501330-1100

**Crimp terminal:** Molex 501334-xxxx

### Specifications

<b>Power supply</b>	$V_{dd} = 5\text{ V} \pm 10\%$
<b>Current consumption</b>	30 mA (not loaded)
<b>Maximum speed</b>	30,000 rpm
<b>Accuracy</b>	Typ. $\pm 0.5^\circ$
<b>Incremental outputs</b>	A, B, Z, A-, B-, Z- (RS422)
<b>Incremental resolutions</b>	256, 512, 1024, 2048, 4096 counts per revolution
<b>Commutation outputs</b>	U, V, W
<b>Number of poles for commutation outputs</b>	2, 4, 6, 8, 10, 12, 14, 16
<b>Temperature</b>	-40 °C to +125 °C
Operating and storage	-40 °C to +105 °C for option 10 (with connector)

For dimensions and installation tolerances please refer to documents RMB20 in [RLS Media center](#).

# RMB23Wx

## Connections

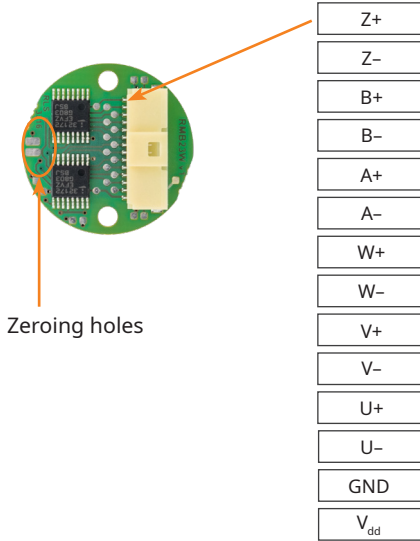

- Z+
- Z-
- B+
- B-
- A+
- A-
- W+
- W-
- V+
- V-
- U+
- U-
- GND
- V<sub>dd</sub>

**Connector on board**  
Molex 501568-1107  
**Mating connector** (Not provided)  
**Shell:** Molex 501330-1100  
**Crimp terminal:** Molex 501334-xxxx

## Specifications

<b>Power supply</b>	V <sub>dd</sub> = 5 V ±10 %
<b>Current consumption</b>	30 mA (not loaded)
<b>Maximum speed</b>	30,000 rpm
<b>Accuracy</b>	Typ. ±0.5°
<b>Incremental outputs</b>	A, B, Z, A-, B-, Z- (RS422)
<b>Incremental resolutions</b>	256, 512, 1024, 2048, 4096 counts per revolution
<b>Commutation outputs</b>	U, V, W, U-, V-, W- (RS422)
<b>Number of poles for commutation outputs</b>	2, 4, 6, 8, 10, 12, 14, 16
<b>Temperature</b> Operating and storage	-40 °C to +105 °C (Limited by connector. All other components used are specified for operation from -40 °C to +125 °C)

## Dimensions and installation tolerance

Dimensions and tolerances are in mm. Dimensions without tolerance values are in accordance with ISO 2768-m.

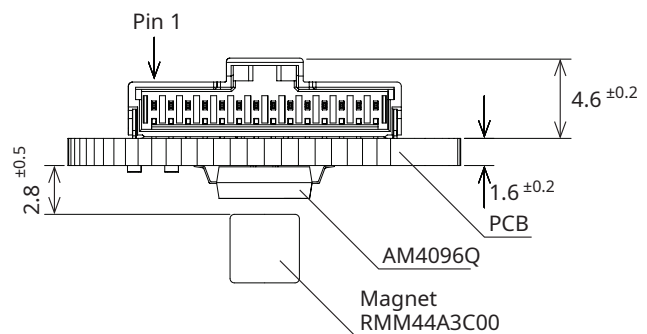
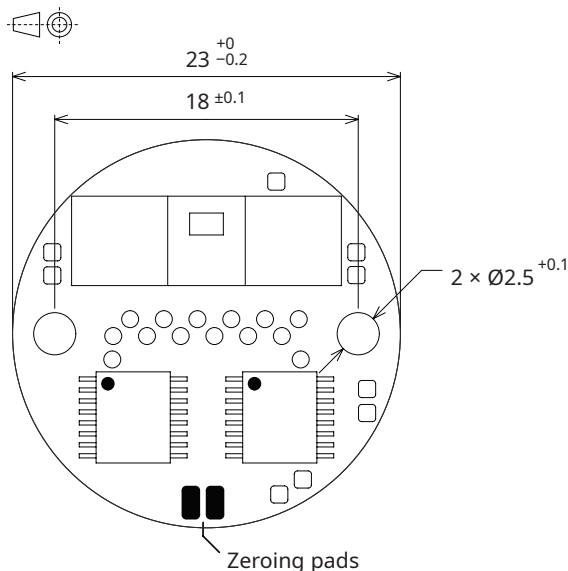

## RMC22Ux

### Connections

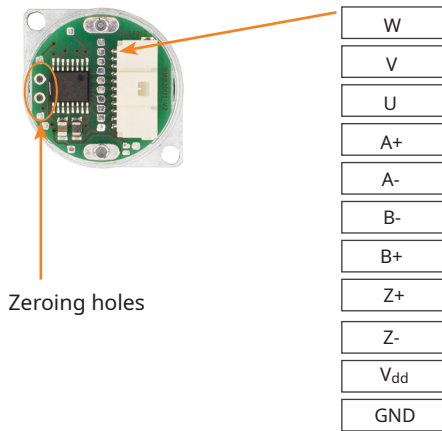

#### Connector on board

Molex 501568-1107

**Mating connector** (Not provided)

**Shell:** Molex 501330-1100

**Crimp terminal:** Molex 501334-xxxx

### Specifications

<b>Power supply</b>	$V_{dd} = 5\text{ V} \pm 10\%$
<b>Current consumption</b>	30 mA (not loaded)
<b>Maximum speed</b>	30,000 rpm
<b>Accuracy</b>	Typ. $\pm 0.5^\circ$
<b>Hysteresis</b>	$0.17^\circ$
<b>Incremental outputs</b>	A, B, Z, A-, B-, Z- (RS422)
<b>Incremental resolutions</b>	256, 512, 1024, 2048, 4096 cpr
<b>Commutation outputs</b>	U, V, W ( $\pm 24\text{ mA}$ output drive)
<b>Number of poles for commutation outputs</b>	2, 4, 6, 8, 10, 12, 14, 16
<b>Temperature</b> Operating and storage	$-40\text{ }^\circ\text{C}$ to $+105\text{ }^\circ\text{C}$ (Limited by connector. All other components used are specified for operation from $-40\text{ }^\circ\text{C}$ to $+125\text{ }^\circ\text{C}$ )
<b>Mass</b>	22 g

For dimensions and installation tolerances please refer to document RMC22D01 in [RLS Media center](#).



## RMC35Ux

### Connections

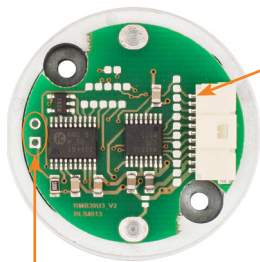

Zeroing holes

W
V
U
A+
A-
B-
B+
Z+
Z-
V <sub>dd</sub>
GND

#### Connector on board

Molex 501568-1107

**Mating connector** (Not provided)

**Shell:** Molex 501330-1100

**Crimp terminal:** Molex 501334-xxxx

### Specifications

<b>Power supply</b>	$V_{dd} = 5\text{ V} \pm 10\%$
<b>Current consumption</b>	40 mA (not loaded)
<b>Maximum speed</b>	Typ. $\pm 0.5^\circ$
<b>Accuracy</b>	$0.18^\circ$
<b>Hysteresis</b>	30,000 rpm
<b>Incremental outputs</b>	A, B, Z, A-, B-, Z- (RS422)
<b>Incremental resolutions</b>	256, 320, 400, 500, 512, 800, 1000, 1024, 1600, 2000, 2048, 4096, 8192 cpr
<b>Commutation outputs</b>	U, V, W ( $\pm 24\text{ mA}$ output drive)
<b>Number of poles for commutation outputs</b>	2, 4, 6, 8, 10, 12, 14, 16
<b>Temperature</b> Operating and storage	$-40\text{ }^\circ\text{C}$ to $+105\text{ }^\circ\text{C}$ (Limited by connector. All other components used are specified for operation from $-40\text{ }^\circ\text{C}$ to $+125\text{ }^\circ\text{C}$ )
<b>Mass</b>	45 g

For dimensions and installation tolerances please refer to document RMC35D01 in [RLS Media center](#).

## RMB28Ux / RMF44Ux / RMF58Ux

### Connections

Board A, with pads:

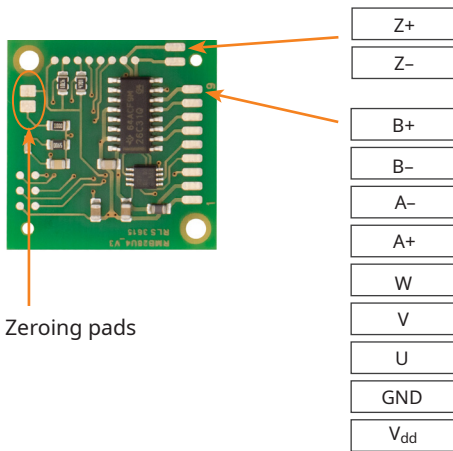

Board A, with Molex connector:

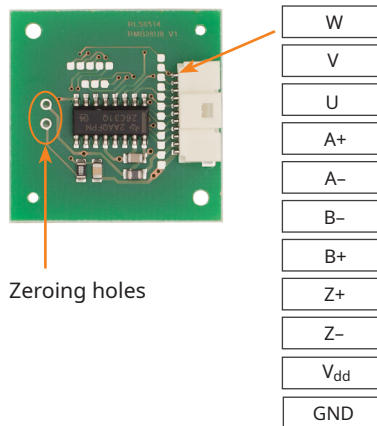

Board B, with pads:

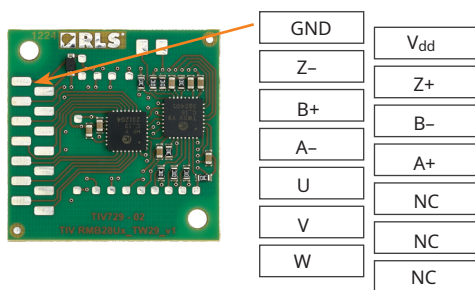

Board B, with Molex connector:

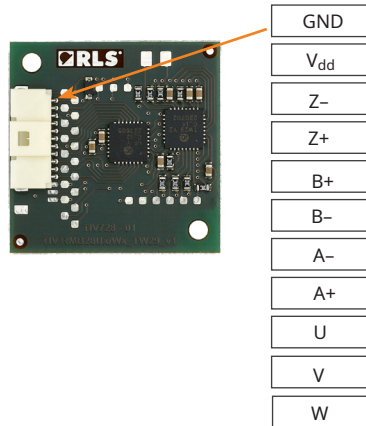

**Connector on board**  
Molex 501568-1107  
**Mating connector** (Not provided)  
**Shell:** Molex 501330-1100  
**Crimp terminal:** Molex 501334-xxxx

Image may not represent actual product as components can vary based on chosen resolution.

### Specifications

<b>Power supply</b>	V <sub>dd</sub> = 5 V ±10 %
<b>Current consumption</b>	<b>Board A:</b> 35 mA (not loaded) <b>Board B:</b> 65 mA (not loaded)
<b>Maximum speed</b>	30,000 rpm
<b>Accuracy</b>	Typ. ±0.5°
<b>Incremental outputs</b>	A, B, Z, A-, B-, Z- (RS422)
<b>Incremental resolutions</b>	<b>Board A:</b> 320, 400, 500, 512, 800, 1000, 1024, 1600, 2000, 2048, 4096 counts per revolution <b>Board B:</b> 360, 3600, 4000, 8000, 8192, 10000, 16000, 16384 counts per revolution*
<b>Commutation outputs</b>	U, V, W (±24 mA output drive)
<b>Number of poles for commutation outputs</b>	<b>Board A:</b> 2, 4, 6, 8, 10, 12, 14, 16 <b>Board B:</b> 18, 20, 22, ... 64
<b>Temperature</b> Operating and storage	-40 °C to +125 °C -40 °C to +105 °C for option 12 (with connector)

For dimensions and installation tolerances please refer to document RMBD01 in **RLS Media center**.

\* For other resolutions **contact RLS**.

## RMB28Wx / RMF44Wx / RMF58Wx

### Connections

Board A, with pads or with Molex connector:

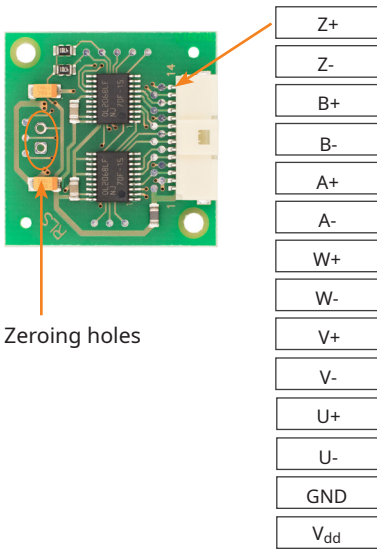

#### Connector on board

Molex 501568-1407

**Mating connector** (Not provided)

**Shell:** Molex 501330-1400

**Crimp terminal:** Molex 501334-xxxx

Board B, with pads:

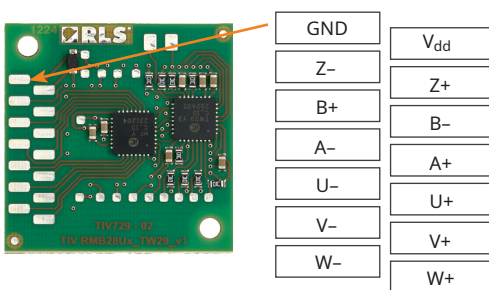

Board B, with Molex connector:

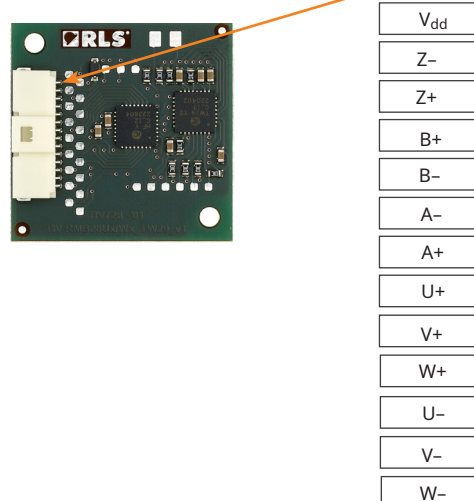

### Specifications

<b>Power supply</b>	$V_{dd} = 5\text{ V} \pm 10\%$
<b>Current consumption</b>	<b>Board A:</b> 35 mA (not loaded) <b>Board B:</b> 65 mA (not loaded)
<b>Maximum speed</b>	30,000 rpm
<b>Accuracy</b>	Typ. $\pm 0.5^\circ$
<b>Incremental outputs</b>	A, B, Z, A-, B-, Z- (RS422)
<b>Incremental resolutions</b>	<b>Board A:</b> 256, 512, 1024, 2048, 4096 <b>Board B:</b> 8192, 16384 counts per revolution*
<b>Commutation outputs</b>	U, V, W, U-, V-, W- (RS422)
<b>Number of poles for commutation outputs</b>	<b>Board A:</b> 2, 4, 6, 8, 10, 12, 14, 16 <b>Board B:</b> 18, 20, 22, ... 64
<b>Temperature</b> Operating and storage	-40 °C to +125 °C -40 °C to +105 °C for option 12 (with connector)

For dimensions and installation tolerances please refer to document RMBD01 in [RLS Media center](#).

\* For other resolutions [contact RLS](#).

## RM44Ux / Wx and RM58Ux / Wx

### Connections

#### RM44



#### RM58



RM44/58Ux		RM44/58Wx	
Function	Wire colour	Function	Wire colour
V <sub>dd</sub>	Red	V <sub>dd</sub>	Red
GND	Blue	GND	Blue
A	Grey	U-	Green/Black
A-	Pink	U+	Black
B	Green	V-	Brown/Black
B-	Yellow	V+	Violet
Z	White	W-	White/Black
Z-	Brown	W+	Yellow/Black
U	Black	A-	Pink
V	Violet	A+	Grey
W	Grey/Violet	B-	Yellow
-	-	B+	Green
-	-	Z-	Brown
-	-	Z+	White

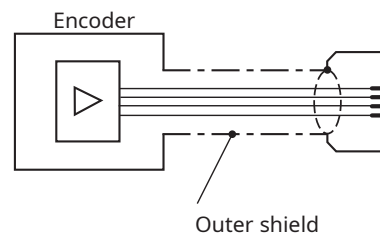

### Specifications

<b>Power supply</b>	V <sub>dd</sub> = 5 V ±10 %
<b>Current consumption</b>	max. 65 mA (not loaded)
<b>Accuracy</b>	Typ. ±0.5°
<b>Hysteresis</b>	0.18°
<b>Maximum speed</b>	30,000 rpm
<b>Incremental outputs</b>	A, B, Z, A-, B-, Z- (RS422)
<b>Incremental resolutions</b>	256, 320, 360, 400, 500, 512, 800, 1000, 1024, 1600, 2000, 2048, 3600, 4000, 4096, 8000, 8192, 10000, 16384 counts per revolution*
<b>Commutation outputs (for Ux)</b>	U, V, W (±24 mA output drive)
<b>Commutation outputs (for Wx)</b>	U, V, W, U-, V-, W- (RS422)
<b>Number of poles for commutation outputs</b>	2, 4, 6, 8, 10, 12, 14, 16, ... 64
<b>Temperature</b>	-40 °C to +125 °C (IP64) -40 °C to +85 °C (IP68)
<b>Mass</b>	45 g

\* RM44 with external zeroing is available with binary resolutions only.

For dimensions and installation tolerances please refer to document RM4458D01 in [RLS Media center](#).

# Zero position setting procedure

## Zeroing with zeroing pads and zeroing holes

Setting the zero position is possible for boards with marked zero pads or holes. It can be easily set by shortening the zeroing pads or holes on the board. After locking the motor at the mechanical zero position short together the two zeroing pads.

The output angle position data can be zeroed at any angle with resolution of 0.0879°.

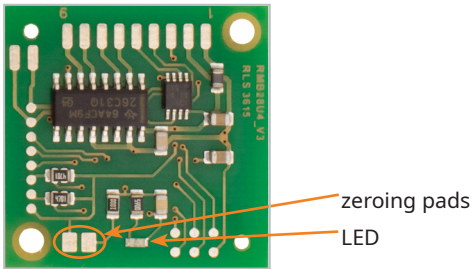

RMB28U zeroing example

The zeroing pads can be shorted to set the zero position of the encoder. If the zeroing is successful, the LED flashes red. Boards that don't have zeroing pads marked don't support zeroing.

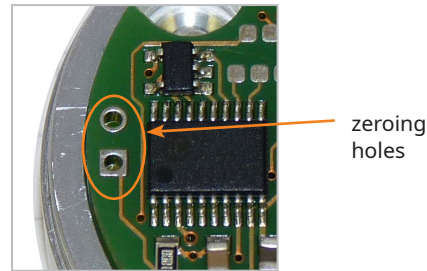

RMC35U zeroing example

The zeroing holes can be shorted to set the zero position of the encoder.

Boards without marked zero pads do not allow zeroing.

## External zeroing

The RM44/58 with external zeroing is designed for setting the encoder zero position by using zero pen. It is designed for power supply voltage of 5 V only. For electrical characteristics and dimensional drawings please refer to document RM4458D01 in [RLS Media center](#).

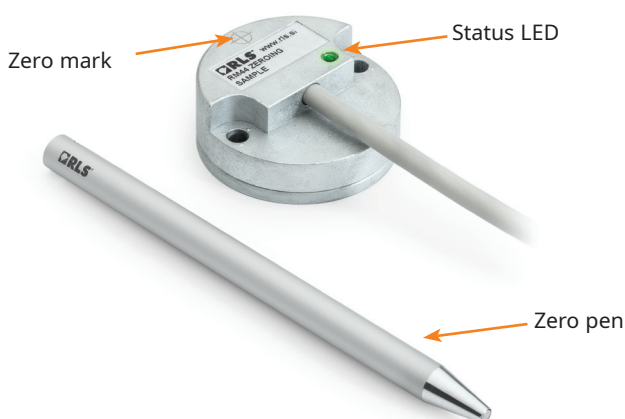

### Status indicator LED

LED	Status
Green	Normal operation
Red	Zero position
No light	Presence of Zero pen

1. Install the magnetic actuator and RM44/58 encoder.  
For more information please refer to document RM4458 in [RLS Media center](#).
2. Set the mechanical zero position.
3. Use the zero pen to set the encoder zero position (see image):
  - 3.1 Touch the Zero mark with the apex of the Zero pen - the status LED goes off.
  - 3.2 Hold the Zero pen for 3 seconds.
  - 3.3 The new Zero position is set when status LED goes RED.

# Part numbering

## RMB29Ex commutation

**RMB29 Ex 12B S 66**

### Ex - UVW + incremental (no line drivers), 5 V

- EA** - One period per revolution (2 poles)
- EB** - Two periods per revolution (4 poles)
- EC** - Three periods per revolution (6 poles)
- ED** - Four periods per revolution (8 poles)
- EE** - Five periods per revolution (10 poles)
- EF** - Six periods per revolution (12 poles)
- EG** - Seven periods per revolution (14 poles)
- EH** - Eight periods per revolution (16 poles)

### Resolution

**12B** - 4,096 counts per revolution

### Shape

**S** - Square

### Special requirements

- 66** - Push pull UVW, no incremental (with Molex connector and conformal coating)
- 6A** - Push pull UVW, no incremental (without connector and conformal coating)

## Table of available combinations

Series	Output type	Resolution	Shape	Special requirements
<b>RMB29</b>	EA / EB / EC / ED / EE / EF / EG / EH	12B	S	66 / 6A

## RMB20Ux

	RMB20	UA	09B	C	10
<b>Ux - Commutation single ended + incremental with line driver output type</b>					
<b>UA</b> - One period per revolution (2 poles)					
<b>UB</b> - Two periods per revolution (4 poles)					
<b>UC</b> - Three periods per revolution (6 poles)					
<b>UD</b> - Four periods per revolution (8 poles)					
<b>UE</b> - Five periods per revolution (10 poles)					
<b>UF</b> - Six periods per revolution (12 poles)					
<b>UG</b> - Seven periods per revolution (14 poles)					
<b>UH</b> - Eight periods per revolution (16 poles)					
<b>Resolution</b>					
<b>08B</b> - 256 counts per revolution					
<b>09B</b> - 512 counts per revolution					
<b>10B</b> - 1,024 counts per revolution					
<b>11B</b> - 2,048 counts per revolution					
<b>12B</b> - 4,096 counts per revolution					
<b>Shape</b>					
<b>C</b> - Circular					
<b>Special requirements</b>					
<b>00</b> - Without connector					
<b>10</b> - Molex connector type 501568-1107*					
* Mating connector not provided.					

### Table of available combinations

Series	Output type	Resolution	Shape	Special requirements
RMB20	UA / UB / UC / UD / UE / UF / UG / UH	12B / 11B / 10B / 09B / 08B	C	00 / 10

**RMB23Wx (commutation complementary and incremental complementary)**

**RMB23    WA    09B    C    12**

**Wx - Commutation with line driver + incremental with line driver**

- WA** - One period per revolution (2 poles)
- WB** - Two periods per revolution (4 poles)
- WC** - Three periods per revolution (6 poles)
- WD** - Four periods per revolution (8 poles)
- WE** - Five periods per revolution (10 poles)
- WF** - Six periods per revolution (12 poles)
- WG** - Seven periods per revolution (14 poles)
- WH** - Eight periods per revolution (16 poles)

**Resolution**

- 08B** - 256 counts per revolution
- 09B** - 512 counts per revolution
- 10B** - 1,024 counts per revolution
- 11B** - 2,048 counts per revolution
- 12B** - 4,096 counts per revolution

**Shape**

- C** - Circular

**Special requirements**

- 12** - Molex connector type 501568-1407\*

\* Mating connector not provided.

**Table of available combinations**

Series	Output type	Resolution	Shape	Special requirements
<b>RMB23</b>	WA / WB / WC / WD / WE / WF / WG / WH	12B / 11B / 10B / 09B / 08B	C	12



**RMB28Ux / RMF44Ux / RMF58Ux and RMB28Wx / RMF44Wx / RMF58Wx (commutation, commutation complementary and incremental complementary)**

**RMB28    W    A    09B    S    10**

**Series**

- RMB28** - Rotary magnetic board with 28 mm side
- RMF44** - Rotary magnetic board on flange with 44 mm diameter aluminium flange
- RMF58** - Rotary magnetic board on flange with 58 mm diameter aluminium flange

**Output type**

- U** - Commutation single ended + incremental with line driver
- W** - Commutation with line driver + incremental with line driver

**UVW output configuration**

- |  |  |
|--|--|
| <ul style="list-style-type: none"> <li><b>A</b> - 1 period per revolution (2 poles)</li> <li><b>B</b> - 2 periods per revolution (4 poles)</li> <li><b>C</b> - 3 periods per revolution (6 poles)</li> <li><b>D</b> - 4 periods per revolution (8 poles)</li> <li><b>E</b> - 5 periods per revolution (10 poles)</li> <li><b>F</b> - 6 periods per revolution (12 poles)</li> <li><b>G</b> - 7 periods per revolution (14 poles)</li> <li><b>H</b> - 8 periods per revolution (16 poles)</li> <li><b>I</b> - 9 periods per revolution (18 poles)</li> <li><b>J</b> - 10 periods per revolution (20 poles)</li> <li><b>K</b> - 11 periods per revolution (22 poles)</li> <li><b>L</b> - 12 periods per revolution (24 poles)</li> <li><b>M</b> - 13 periods per revolution (26 poles)</li> <li><b>N</b> - 14 periods per revolution (28 poles)</li> <li><b>P</b> - 15 periods per revolution (30 poles)</li> <li><b>R</b> - 16 periods per revolution (32 poles)</li> </ul> | <ul style="list-style-type: none"> <li><b>S</b> - 17 periods per revolution (34 poles)</li> <li><b>T</b> - 18 periods per revolution (36 poles)</li> <li><b>U</b> - 19 periods per revolution (38 poles)</li> <li><b>V</b> - 20 periods per revolution (40 poles)</li> <li><b>W</b> - 21 periods per revolution (42 poles)</li> <li><b>Y</b> - 22 periods per revolution (44 poles)</li> <li><b>Z</b> - 23 periods per revolution (46 poles)</li> <li><b>1</b> - 24 periods per revolution (48 poles)</li> <li><b>2</b> - 25 periods per revolution (50 poles)</li> <li><b>3</b> - 26 periods per revolution (52 poles)</li> <li><b>4</b> - 27 periods per revolution (54 poles)</li> <li><b>5</b> - 28 periods per revolution (56 poles)</li> <li><b>6</b> - 29 periods per revolution (58 poles)</li> <li><b>7</b> - 30 periods per revolution (60 poles)</li> <li><b>8</b> - 31 periods per revolution (62 poles)</li> <li><b>9</b> - 32 periods per revolution (64 poles)</li> </ul> |
|--|--|

**Resolution**

- 08B** - 256 counts per revolution
- 09B** - 512 counts per revolution
- 10B** - 1,024 counts per revolution
- 11B** - 2,048 counts per revolution
- 12B** - 4,096 counts per revolution
- 13B** - 8,192 counts per revolution
- 14B** - 16,384 counts per revolution

For **Ux** (counts per revolution):

Decimal			Binary		
<b>D32</b> - 320	<b>1D0</b> - 1000	<b>8D0</b> - 8000	<b>08B</b> - 256	<b>13B</b> - 8192	
<b>D36</b> - 360	<b>1D6</b> - 1600	<b>10D</b> - 10000	<b>09B</b> - 512	<b>14B</b> - 16384	
<b>D40</b> - 400	<b>2D0</b> - 2000	<b>16D</b> - 16000	<b>10B</b> - 1024		
<b>D50</b> - 500	<b>3D6</b> - 3600		<b>11B</b> - 2048		
<b>D80</b> - 800	<b>4D0</b> - 4000		<b>12B</b> - 4096		

**Shape**

- S** - Square (for **RMB28** only)
- A** - Standard 44 mm diameter aluminium flange (for **RMF44** only)

**Special requirements**

- 10** - None (standard)
- 12** - Molex connector type 501568-1407\*

\* Mating connector not provided.

**Table of available combinations**

Series	Output type	Resolution	Shape	Special requirements
<b>RMB28</b>	UA / UB / UC / UD / UE / UF / UG / UH / UI / UJ / UK / UL / UM / UN / UP / UR / US / UT / UU / UV / UW / UY / UZ / U1 / U2 / U3 / U4 / U5 / U6 / U7 / U8 / U9	2D0 / 1D6 / 1D0 / D80 / D50 / D40 / D32 / 13B / 12B / 11B / 10B / 09B / 08B / D36 / 3D6 / 4D0 / 8D0 / 10D / 16D / 14B	S	10 / 12
	WA / WB / WC / WD / WE / WF / WG / WH / WI / WJ / WK / WL / WM / WN / WP / WR / WS / WT / WU / WV / WW / WY / WZ / W1 / W2 / W3 / W4 / W5 / W6 / W7 / W8 / W9	14B / 13B / 12B / 11B / 10B / 09B / 08B		

Series	Output type	Resolution	Shape	Special requirements
<b>RMF44/ RMF58</b>	UA / UB / UC / UD / UE / UF / UG / UH / UI / UJ / UK / UL / UM / UN / UP / UR / US / UT / UU / UV / UW / UY / UZ / U1 / U2 / U3 / U4 / U5 / U6 / U7 / U8 / U9	2D0 / 1D6 / 1D0 / D80 / D50 / D40 / D32 / 13B / 12B / 11B / 10B / 09B / 08B D36 / 3D6 / 4D0 / 8D0 / 10D / 16D / 14B	A	10 / 12
	WA / WB / WC / WD / WE / WF / WG / WH / WI / WJ / WK / WL / WM / WN / WP / WR / WS / WT / WU / WV / WW / WY / WZ / W1 / W2 / W3 / W4 / W5 / W6 / W7 / W8 / W9	14B / 13B / 12B / 11B / 10B / 09B / 08B		

## RMC22Ux and RMC35Ux (commutation and incremental complementary)

	RMC22	U	A	09B	AA	10																																				
<b>Series</b>	<p><b>RMC22</b> - Rotary magnetic compact encoder with 22 mm body</p> <p><b>RMC35</b> - Rotary magnetic compact encoder with 35 mm body</p>																																									
<b>Output type</b>	<p><b>U</b> - Commutation single ended + incremental with line driver</p>																																									
<b>UVW output configuration</b>	<p><b>A</b> - One period per revolution (2 poles)</p> <p><b>B</b> - Two periods per revolution (4 poles)</p> <p><b>C</b> - Three periods per revolution (6 poles)</p> <p><b>D</b> - Four periods per revolution (8 poles)</p> <p><b>E</b> - Five periods per revolution (10 poles)</p> <p><b>F</b> - Six periods per revolution (12 poles)</p> <p><b>G</b> - Seven periods per revolution (14 poles)</p> <p><b>H</b> - Eight periods per revolution (16 poles)</p>																																									
<b>Resolution</b>	<table border="0"> <tr> <td>For <b>RMC22Ux</b>:</td> <td colspan="5">For <b>RMC35Ux</b> (counts per revolution):</td> </tr> <tr> <td><b>08B</b> - 256 counts per revolution</td> <td colspan="2" style="text-align: center;"><b>Decimal</b></td> <td colspan="3" style="text-align: center;"><b>Binary</b></td> </tr> <tr> <td><b>09B</b> - 512 counts per revolution</td> <td><b>D32</b> - 320</td> <td><b>D80</b> - 800</td> <td><b>2D0</b> - 2000</td> <td><b>08B</b> - 256</td> <td><b>11B</b> - 2048</td> </tr> <tr> <td><b>10B</b> - 1,024 counts per revolution</td> <td><b>D40</b> - 400</td> <td><b>1D0</b> - 1000</td> <td></td> <td><b>09B</b> - 512</td> <td><b>12B</b> - 4096</td> </tr> <tr> <td><b>11B</b> - 2,048 counts per revolution</td> <td><b>D50</b> - 500</td> <td><b>1D6</b> - 1600</td> <td></td> <td><b>10B</b> - 1024</td> <td><b>13B</b> - 8192</td> </tr> <tr> <td><b>12B</b> - 4,096 counts per revolution</td> <td></td> <td></td> <td></td> <td></td> <td></td> </tr> </table>						For <b>RMC22Ux</b> :	For <b>RMC35Ux</b> (counts per revolution):					<b>08B</b> - 256 counts per revolution	<b>Decimal</b>		<b>Binary</b>			<b>09B</b> - 512 counts per revolution	<b>D32</b> - 320	<b>D80</b> - 800	<b>2D0</b> - 2000	<b>08B</b> - 256	<b>11B</b> - 2048	<b>10B</b> - 1,024 counts per revolution	<b>D40</b> - 400	<b>1D0</b> - 1000		<b>09B</b> - 512	<b>12B</b> - 4096	<b>11B</b> - 2,048 counts per revolution	<b>D50</b> - 500	<b>1D6</b> - 1600		<b>10B</b> - 1024	<b>13B</b> - 8192	<b>12B</b> - 4,096 counts per revolution					
For <b>RMC22Ux</b> :	For <b>RMC35Ux</b> (counts per revolution):																																									
<b>08B</b> - 256 counts per revolution	<b>Decimal</b>		<b>Binary</b>																																							
<b>09B</b> - 512 counts per revolution	<b>D32</b> - 320	<b>D80</b> - 800	<b>2D0</b> - 2000	<b>08B</b> - 256	<b>11B</b> - 2048																																					
<b>10B</b> - 1,024 counts per revolution	<b>D40</b> - 400	<b>1D0</b> - 1000		<b>09B</b> - 512	<b>12B</b> - 4096																																					
<b>11B</b> - 2,048 counts per revolution	<b>D50</b> - 500	<b>1D6</b> - 1600		<b>10B</b> - 1024	<b>13B</b> - 8192																																					
<b>12B</b> - 4,096 counts per revolution																																										
<b>Shape</b>	<p><b>AA</b> - Molex 501568-1107</p>																																									
<b>Special requirements</b>	<p><b>10</b> - None (standard)</p>																																									

### Table of available combinations

Series	Output type	Resolution	Shape	Special requirements
RMC22	UA / UB / UC / UD / UE / UF / UG / UH	12B / 11B / 10B / 09B / 08B	AA	10
RMC35		2D0 / 1D6 / 1D0 / D80 / D50 / D40 / D32 / 13B / 12B / 11B / 10B / 09B / 08B		

## RM44Ux / Wx and RM58Ux / Wx (commutation and incremental complementary)

RM44 U A 00 12B 10 F 2 E 10

### Series

- RM44** - Ø44 mm body  
**RM58** - Ø58 mm body

### Output type

- U** - Commutation single ended + incremental with line driver  
**W** - Commutation with line driver + incremental with line driver

### UVW output configuration

- |   |   |
|---|---|
| <b>A</b> - 1 period per revolution (2 poles)    | <b>S</b> - 17 periods per revolution (34 poles) |
| <b>B</b> - 2 periods per revolution (4 poles)   | <b>T</b> - 18 periods per revolution (36 poles) |
| <b>C</b> - 3 periods per revolution (6 poles)   | <b>U</b> - 19 periods per revolution (38 poles) |
| <b>D</b> - 4 periods per revolution (8 poles)   | <b>V</b> - 20 periods per revolution (40 poles) |
| <b>E</b> - 5 periods per revolution (10 poles)  | <b>W</b> - 21 periods per revolution (42 poles) |
| <b>F</b> - 6 periods per revolution (12 poles)  | <b>Y</b> - 22 periods per revolution (44 poles) |
| <b>G</b> - 7 periods per revolution (14 poles)  | <b>Z</b> - 23 periods per revolution (46 poles) |
| <b>H</b> - 8 periods per revolution (16 poles)  | <b>1</b> - 24 periods per revolution (48 poles) |
| <b>I</b> - 9 periods per revolution (18 poles)  | <b>2</b> - 25 periods per revolution (50 poles) |
| <b>J</b> - 10 periods per revolution (20 poles) | <b>3</b> - 26 periods per revolution (52 poles) |
| <b>K</b> - 11 periods per revolution (22 poles) | <b>4</b> - 27 periods per revolution (54 poles) |
| <b>L</b> - 12 periods per revolution (24 poles) | <b>5</b> - 28 periods per revolution (56 poles) |
| <b>M</b> - 13 periods per revolution (26 poles) | <b>6</b> - 29 periods per revolution (58 poles) |
| <b>N</b> - 14 periods per revolution (28 poles) | <b>7</b> - 30 periods per revolution (60 poles) |
| <b>P</b> - 15 periods per revolution (30 poles) | <b>8</b> - 31 periods per revolution (62 poles) |
| <b>R</b> - 16 periods per revolution (32 poles) | <b>9</b> - 32 periods per revolution (64 poles) |

### Shaft size

- 00** - N/A

### Resolution

For **Wx**:

- 08B** - 256 counts per revolution  
**09B** - 512 counts per revolution  
**10B** - 1,024 counts per revolution  
**11B** - 2,048 counts per revolution  
**12B** - 4,096 counts per revolution  
**13B** - 8,192 counts per revolution  
**14B** - 16,384 counts per revolution

For **Ux** (counts per revolution):

Decimal		Binary	
<b>D32</b> - 320	<b>1D0</b> - 1000	<b>8D0</b> - 8000	<b>08B</b> - 256 <b>13B</b> - 8192
<b>D36</b> - 360	<b>1D6</b> - 1600	<b>10D</b> - 10000	<b>09B</b> - 512 <b>14B</b> - 16384
<b>D40</b> - 400	<b>2D0</b> - 2000	<b>16D</b> - 16000	<b>10B</b> - 1024
<b>D50</b> - 500	<b>3D6</b> - 3600		<b>11B</b> - 2048
<b>D80</b> - 800	<b>4D0</b> - 4000		<b>12B</b> - 4096

For **RM44 with external zeroing** (counts per revolution):

- 05Z** - 32    **08Z** - 256    **2D0** - 2000  
**06Z** - 64    **09Z** - 512  
**07Z** - 128    **10Z** - 1024

### Cable length

- 10** - 1.0 meter (or 10 meters if **1M** special requirement is chosen)

### Connector options

- F** - Flying lead (no connector)

### Body style and cable exit

- 2** - Cylindrical body, radial cable exit

### Environment and material

- E** - IP64, die-cast body (Zinc alloy), standard EMC grade (standard)  
**F** - IP68, die-cast body (Zinc alloy), standard EMC grade

### Special requirements

- 10** - None (standard)  
**1M** - Cable length in meters

## Table of available combinations

Series	Output type	Shaft size	Resolution	Cable length	Connector type	Body style	Environment and material	Special requirements
<b>RM44/ RM58</b>	UA / UB / UC / UD / UE / UF / UG / UH / UI / UJ / UK / UL / UM / UN / UP / UR / US / UT / UU / UV / UW / UY / UZ / U1 / U2 / U3 / U4 / U5 / U6 / U7 / U8 / U9	00	2D0 / 1D6 / 1D0 / D80 / D50 / D40 / D36 / D32 / 3D6 / 4D0 / 8D0 / 16D / 10D / 14B / 13B / 12B / 11B / 10B / 09B / 08B	10	F	2	E / F	10 / 1M
	WA / WB / WC / WD / WE / WF / WG / WH / WI / WJ / WK / WL / WM / WN / WP / WR / WS / WT / WU / WV / WW / WY / WZ / W1 / W2 / W3 / W4 / W5 / W6 / W7 / W8 / W9		14B / 13B / 12B / 11B / 10B / 09B / 08B					
<b>RM44Ux with external zeroing</b>	UA / UB / UC / UD / UE / UF / UG / UH		12Z / 11Z / 10Z / 09Z / 08Z / 07Z / 06Z / 05Z					

# Magnetic actuator and magnet ordering information

## Actuator for integration onto shaft

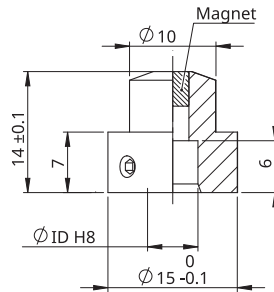
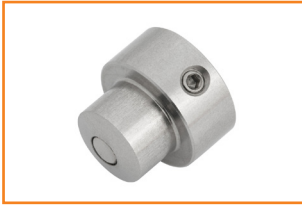

**Shaft** = Ø ID h7

**Fixing:** Grub screw provided

\* Hole diameter for nominal shaft size.

See table on the right for more information on available shaft sizes.

**Part numbers:**

For resolutions up to 9 bit absolute (512 cpr incremental)

<b>RMA04A2A00</b> - ID = Ø4 mm	<b>RMA10A2A00</b> - ID = Ø10 mm
<b>RMA05A2A00</b> - ID = Ø5 mm	<b>RMA19A2A00</b> - ID = Ø3/16" mm
<b>RMA06A2A00</b> - ID = Ø6 mm	<b>RMA25A2A00</b> - ID = Ø1/4" mm
<b>RMA08A2A00</b> - ID = Ø8 mm	<b>RMA37A2A00</b> - ID = Ø3/8" mm

For resolutions from 10 bit absolute (800 cpr incremental) and above

<b>RMA04A3A00</b> - ID = Ø4 mm	<b>RMA10A3A00</b> - ID = Ø10 mm
<b>RMA05A3A00</b> - ID = Ø5 mm	<b>RMA19A3A00</b> - ID = Ø3/16" mm
<b>RMA06A3A00</b> - ID = Ø6 mm	<b>RMA25A3A00</b> - ID = Ø1/4" mm
<b>RMA08A3A00</b> - ID = Ø8 mm	<b>RMA37A3A00</b> - ID = Ø3/8" mm

## Actuator for integration into shaft

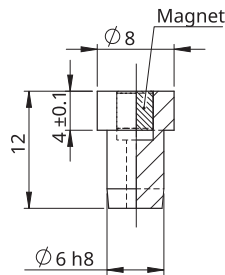

with N-pole marker



**Hole** = Ø6G7

**Fixing:** Adhesive (recommended - LOCTITE 648 or 2701)

**Part numbers:**

For resolutions up to 9 bit absolute (512 cpr incremental)

**RMH06A2A00**

For resolutions from 10 bit absolute (800 cpr incremental) and above

**RMH06A3A00**

With N-pole marker scribed to a ±5° accuracy:

For resolutions up to 9 bit absolute (512 cpr incremental)

**RMH06A2A02**

For resolutions from 10 bit absolute (800 cpr incremental) and above

**RMH06A3A02**

## Magnet for direct recessing in non-ferrous shafts

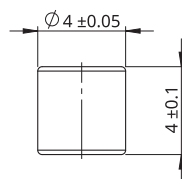

**Fixing:** Adhesive (recommended - LOCTITE 648 or 2701)

**Part numbers:**

For resolutions up to 9 bit absolute (512 cpr incremental)

**RMM44A2A00** (individually packed) - for sample quantities only  
**RMM44A2C00** (packed in tubes)

For resolutions from 10 bit absolute (800 cpr incremental) and above

**RMM44A3A00** (individually packed) - for sample quantities only  
**RMM44A3C00** (packed in tubes)

If you need a shaft encoder, please refer to the [RE58 data sheet](#), which describes how the RM44 can be converted into an RE58 by adding a flange.

## Accessories



Zeroing pen  
**ZEROPEN00**

### For Ux output



Cable assembly, 12 core  
**ACC001** cable assembly 0.3 m  
**ACC002** cable assembly 0.5 m  
**ACC003** cable assembly 1 m



Cable assembly, 14 core  
**ACC020** cable assembly 30 cm

## Cable assemblies

### Cable specifications for connection of Molex 501330-1100, 12 core

<b>Part numbers</b>	ACC001 (cable length: 30 cm) ACC002 (cable length: 50 cm) ACC003 (cable length: 100 cm) ACC026 (cable length: 3 m)
<b>Connector</b>	Molex 501330-1100, 11 pins
<b>Wire diameter</b>	AWG26 (0.14 mm <sup>2</sup> )
<b>Sheath color</b>	Grey (RAL7032)
<b>Rated voltage</b>	250 V
<b>Operating temperature</b>	From -30 °C to +125 °C
<b>Environmental conformation</b>	RoHS conform 73/23/EWG-Guideline CE conform Halogen free

## Dimensions

Dimensions and tolerances in mm.

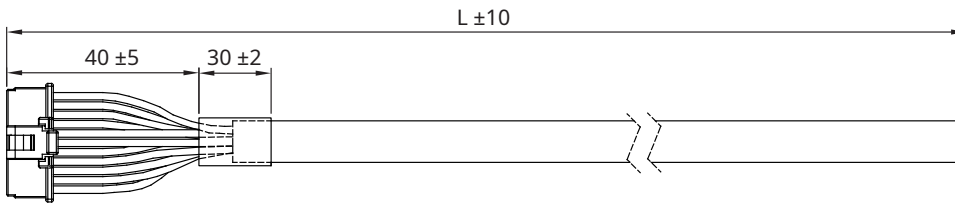

Pin	Wire color
1	Blue
2	Red
3	Brown
4	White
5	Green
6	Yellow
7	Grey
8	Pink
9	Black
10	Violet
11	Grey/Pink

## Cable specifications for connection of Molex 501568-1407, 14 core

<b>Part numbers</b>	ACC020 (cable length: 30 cm)
<b>Connector</b>	Molex 501568-1407, 14 pin
<b>Wire diameter</b>	AWG28
<b>Rated voltage</b>	300 V
<b>Operating temperature</b>	From -40 °C to +125 °C

## Dimensions

Dimensions and tolerances in mm.

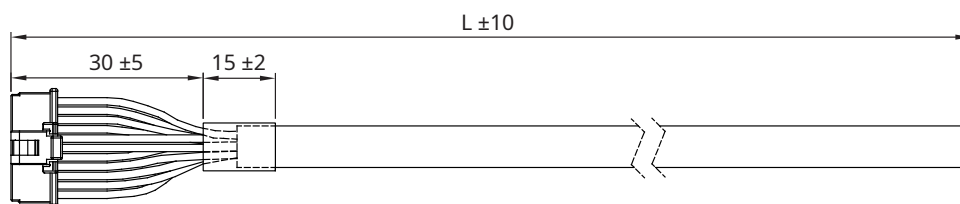

Pin	Wire color
1	Red
2	Blue
3	Green/Black
4	Black
5	Brown/Black
6	Violet
7	White/Black
8	Yellow/Black
9	Pink
10	Grey
11	Yellow
12	Green
13	Brown
14	White



## Head office

---

### RLS Merilna tehnika d.o.o.

Poslovna cona Žeje pri Komendi  
Pod vrbami 2  
SI-1218 Komenda  
Slovenia

T +386 1 5272100  
E [mail@rls.si](mailto:mail@rls.si)  
[www.rls.si](http://www.rls.si)

## Global support

---

Visit our [website](#) to contact your nearest sales representative.

## Document issues

---

Issue	Date	Page	Description
5	27. 9. 2021	10	RM44 dimensions amended
6	12. 2. 2024	2, 11, 12, 20	RM58 option added
		2, 9, 18	RMF58 option added
7	28. 11. 2024	General	New design

This product is not designed or intended for use outside the environmental limitations and operating parameters expressly stated on the product's datasheet. Products are not designed or intended for use in medical, military, aerospace, automotive or oil & gas applications or any safety-critical applications where a failure of the product could cause severe environmental or property damage, personal injury or death. Any use in such applications must be specifically agreed to by seller in writing, and is subject to such additional terms as the seller may impose in its sole discretion. Use of products in such applications is at buyer's own risk, and buyer will indemnify and hold harmless seller and its affiliates against any liability, loss, damage or expense arising from such use. Information contained in this datasheet was derived from product testing under controlled laboratory conditions and data reported thereon is subject to the stated tolerances and variations, or if none are stated, then to tolerances and variations consistent with usual trade practices and testing methods. The product's performance outside of laboratory conditions, including when one or more operating parameters is at its maximum range, may not conform to the product's datasheet. Further, information in the product's datasheet does not reflect the performance of the product in any application, end-use or operating environment buyer or its customer may put the product to. Seller and its affiliates make no recommendation, warranty or representation as to the suitability of the product for buyer's application, use, end-product, process or combination with any other product or as to any results buyer or its customer might obtain in their use of the product. Buyer should use its own knowledge, judgment, expertise and testing in selecting the product for buyer's application, end-use and/or operating environment, and should not rely on any oral or written statement, representation, or samples made by seller or its affiliates for any purpose. EXCEPT FOR THE WARRANTIES EXPRESSLY SET FORTH IN THE SELLER'S TERMS AND CONDITIONS OF SALE, SELLER MAKES NO WARRANTY EXPRESS OR IMPLIED WITH RESPECT TO THE PRODUCT, INCLUDING ANY WARRANTY OF MERCHANTABILITY OR FITNESS FOR ANY PARTICULAR PURPOSE, WHICH ARE DISCLAIMED AND EXCLUDED. All sales are subject to seller's exclusive terms and conditions of sale which, where the seller is (a) RLS Merilna tehnika d. o. o., are available at <https://www.rls.si/eng/salesterms>, (b) Renishaw, Inc., are available at <https://www.renishaw.com/legal/en/-42186>, or (c) another person, are available on request, and in each case, are incorporated herein by reference, and are the exclusive terms of sale. No other terms and conditions apply. Buyer is not authorized to make any statements or representations that expand upon or extend the environmental limitations and operating parameters of the products, or which imply permitted usage outside of that expressly stated on the datasheet or agreed to in writing by seller.

RLS Merilna tehnika d. o. o. has made considerable effort to ensure the content of this document is correct at the date of publication but makes no warranties or representations regarding the content. RLS Merilna tehnika d. o. o. excludes liability, howsoever arising, for any inaccuracies in this document. © 2024 RLS d. o. o.