

AS

Absolute Magnetic Scales

RESISTANT TO
COOLANTS AND
OILS

UP TO 16.3 m
LENGTH

TRACK
SECTION
SYSTEM
(TRS)

The robust absolute magnetic scales consist of a stainless steel carrier and an elastomer-bonded ferrite. Three options are available, the AS10, DS19 and SAS10 magnetic scales. The flexible AS10 and DS19 scales are 10 and 15 mm wide with the exposed elasto-ferrite layer bonded to a flexible stainless steel carrier. The SAS10 is a solid scale available in predefined lengths. It can be fully enclosed making it suitable for harsh environments where oils or coolants are present.



Features and benefits

- ▶ Excellent resistance to dirt, dust and humidity
- ▶ Totally enclosed SAS10 scale protected from contaminants
- ▶ Optional protective cover foil for AS10 and DS19 scale
- ▶ Easy installation with adhesive tape, end-clamps, or track system (TRS)
- ▶ Partial arc application with DS19 scale



INDUSTRIAL AUTOMATION



LINEAR MOTOR



MEDICAL

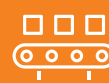

ASSEMBLY LINES



MACHINE TOOL

General information

The AS10 and SAS10 absolute magnetic scales are compatible with the RLS LA11 and LA12 readheads. The LF11 readhead is compatible with the AS10 magnetic scale only.

The DS19 absolute magnetic scale is compatible with Artos™ readhead and it supports linear and partial arc applications. The DS19 magnetic scale can be attached to shafts with larger diameters from 200 mm upwards. The use of the DS19 magnetic scale does not support a full 360° rotation of the shaft, but is intended for applications with large shafts where a full rotation is not required. The DS19 absolute scale is currently available up to 2 m long. For more information about Artos readheads refer to **DRD01** and **DBD01**.

SAS10 scales are available in predefined lengths up to 1.36 m (1.288 m measuring length). For longer scale options (>1.3 m) please **contact RLS**. The AS10 scale is available in lengths up to 16.3 m.

The SAS10 scale comes in two versions, one fully welded and another with the elasto-ferrite layer exposed. The welded version is designed for harsh environments where contamination with industrial compounds is possible, while the exposed version is intended for applications where higher accuracy is required.

Absolute scale variants

AS10 and DS19
(optionally with cover foil)

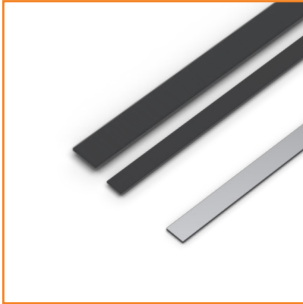

TRS option (AS10)



SAS10 with elasto-ferrite
layer exposed (option A)



SAS10 fully welded (option C)



Selection guide

Scale	Accuracy at 0.2 mm ride height	Compatibility with readheads			
		LA11	LA12	LF11	Artos
AS10	±30 µm/m*	✓	✓	✓	-
SAS10	±20 µm/m*	✓	✓	-	-
DS19	±10 µm/m*	-	-	-	✓

* Check the accuracy as a function of ride height and lateral offset in AST01 at **RLS Media center**.

More about LF11, LA11, LA12 and Artos readheads can be found at **RLS Media center**.

Storage and handling

Storage temperature



AS10 and DS19: -40 °C to +60 °C
SAS10: -40 °C to +75 °C

Operating temperature



AS10 and DS19: -40 °C to +100 °C
SAS10: -40 °C to +75 °C

Humidity



85% non-condensing

The storage temperature of the AS10 and DS19 scale is lower than the operating temperature. This limit has been established because the AS10 and DS19 scales may be damaged within 2 months if exposed to higher temperatures. Once the scale is straightened and firmly attached, it can be exposed to the operating temperatures.

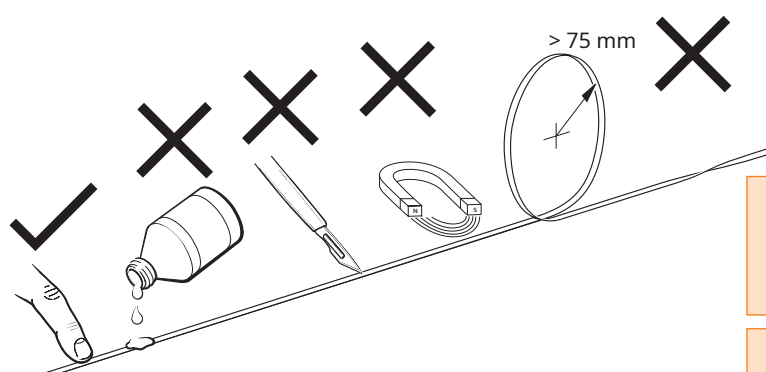

The minimum storage bending radius of the AS10 and DS19 scales is 75 mm.

It is strongly recommended that the scale is factory cut at RLS otherwise the product warranty does not apply.

The magnetic scale should not be exposed to magnetic field densities higher than 25 mT on its surface, as this may damage the scale.

Chemical resistance

The use of alcohol for cleaning is considered safe for AS10, DS19 and SAS10 exposed version, but it is not allowed to immerse the scales in alcohol. Furthermore, the scale surface print may disappear if the scale is not carefully cleaned.

SAS10 welded cover foil completely encapsulates the scale and protects it from aggressive industrial chemicals

For more information on chemical resistance **contact RLS**.

Packaging

The type of packaging depends on the length and quality of the magnetic scale. AS10 scales shorter than 330 mm are packed individually in a plastic tube, while rolled packaging is used for longer lengths. DS19 scales are always packed individually in tube or spiral packaging, depending on scale length. This prevents demagnetization of the scale by maintaining the distance between the scale rolls.

When option B, H or N is selected for the AS10 scale, the protective cover foil is supplied with the scale. The cover foil for the DS19 scale must be ordered separately. The cover foil is not pre-installed on the scale.

The SAS10 scales are packed individually in wooden boxes.

AS10 individual packaging (up to and including 20 pieces)

Magnetic Scale Length	Type of packaging
≤ 330 mm	Plastic tube
> 330 mm	Rolled

AS10 bulk packaging (more than 20 pieces)

Magnetic Scale Length	Type of packaging
≤ 600 mm	Plastic tube
> 600 mm	Rolled

DS19 individual packaging

Magnetic Scale Length	Type of packaging
≤ 300 mm	Plastic tube
> 300 mm	Rolled

All AS magnetic scales have 12 months shelf life and should be installed within this period.

Magnetic scale design

Structure of AS10 and DS19 absolute magnetic scale

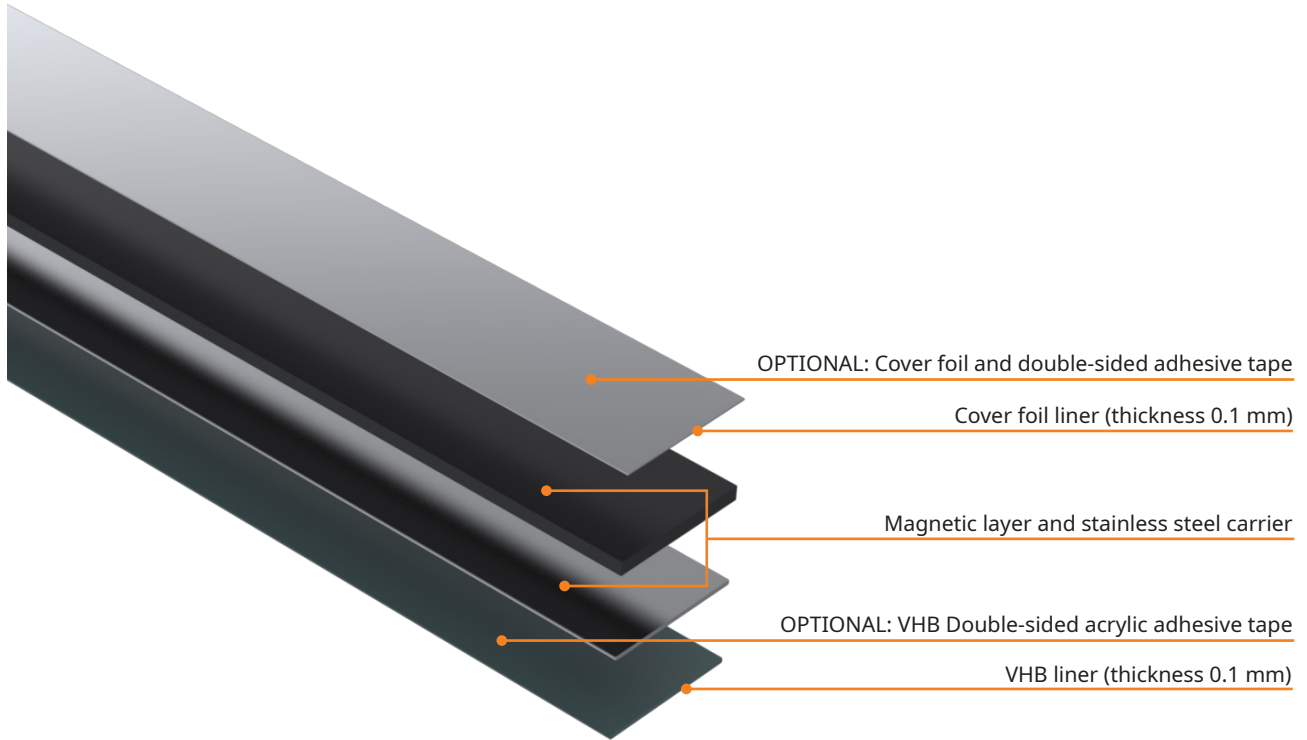

Structure of SAS10 absolute magnetic scale on a solid substrate

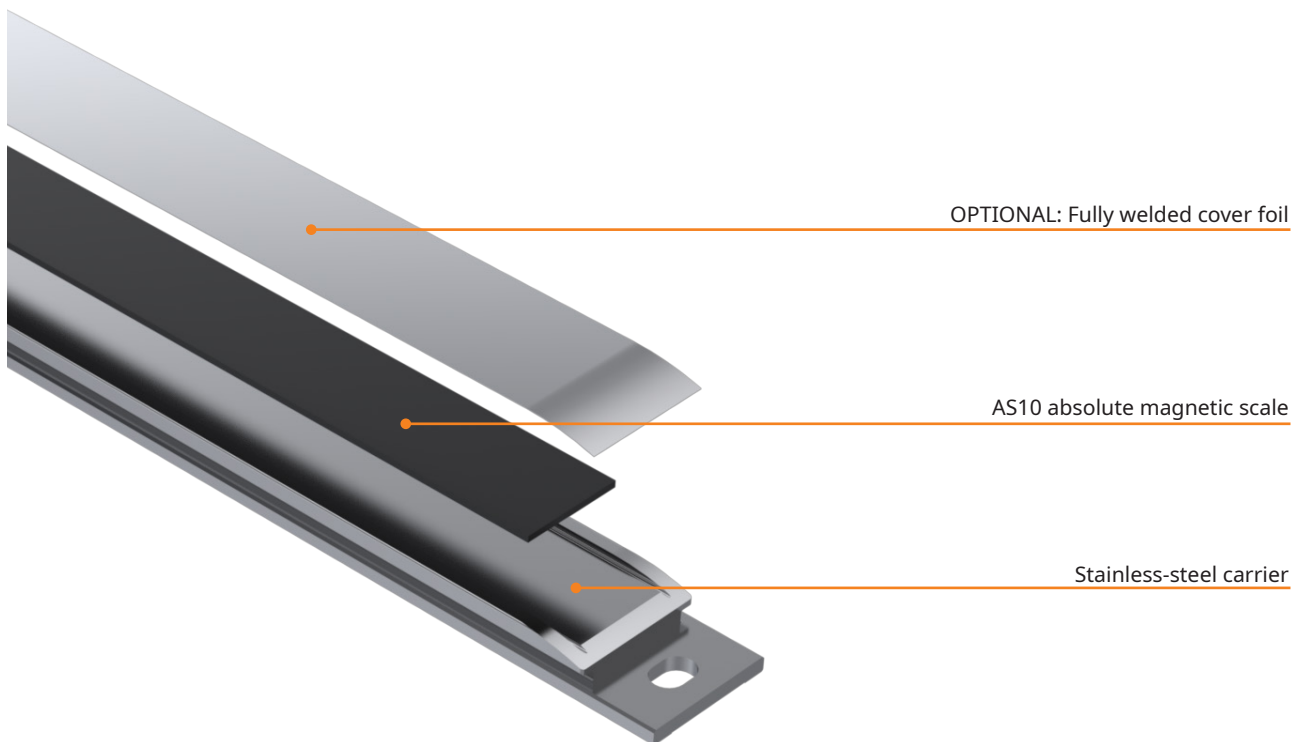

AS10 appearance and print

The orientation of the magnetised incremental track and absolute track is always the same, relative to the scale print as shown in the figure below.

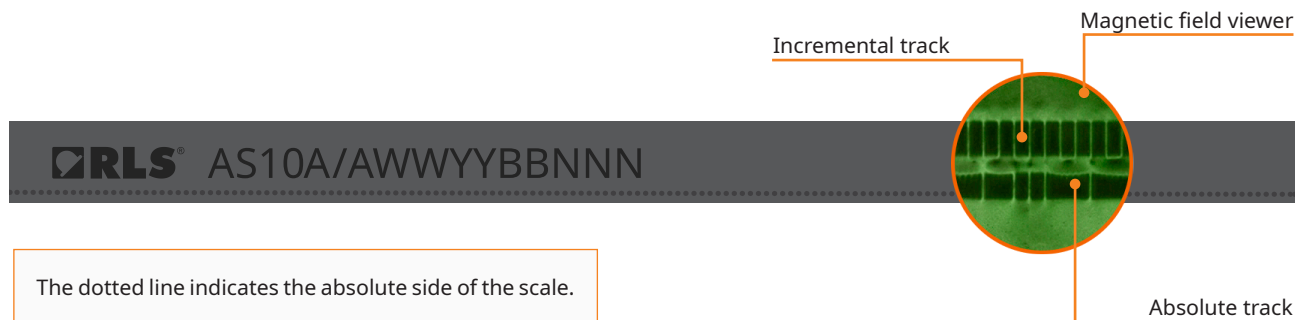

The dotted line indicates the absolute side of the scale.

AS10 scale surface print description

Scale surface print appears every 100 mm and contains the RLS logo and the designator described below. If the scale is shorter than 100 mm it does not contain the print but just the dotted line with which the absolute side of the scale can be determined.

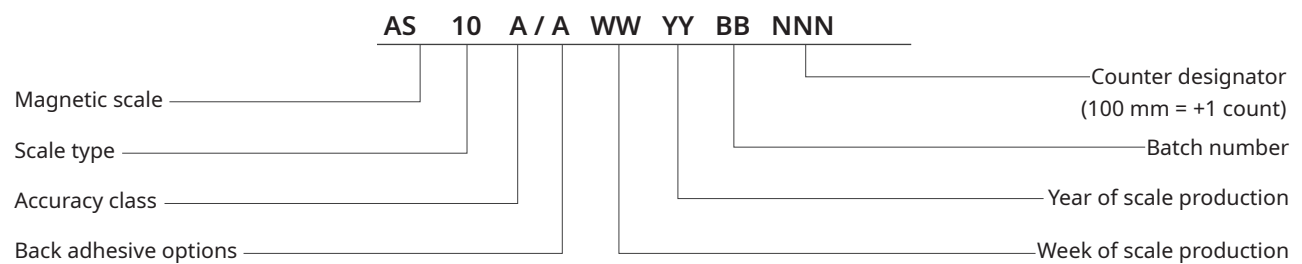

DS19 appearance and print

The orientation of the magnetised incremental track and absolute track is always the same, relative to the scale print as shown in the figure below. The dotted line indicates the absolute side of the scale.



The dotted line indicates the absolute side of the scale.

DS19 scale surface print description

Scale surface print appears every 100 mm and contains the RLS logo and the designator described below. If the scale is shorter than 100 mm it does not contain the print but just the dotted line with which the absolute side of the scale can be determined.

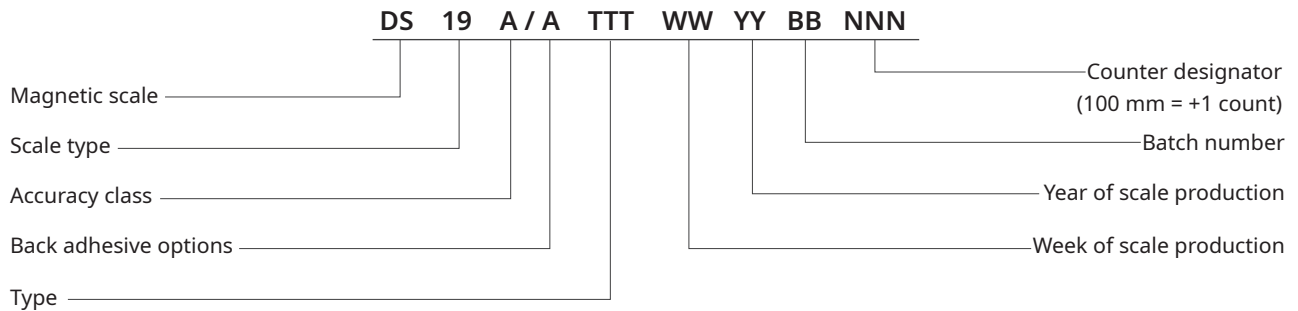

SAS10 appearance and print

The orientation of the magnetised incremental track and absolute track is always the same, relative to the scale print as shown in the figure below.

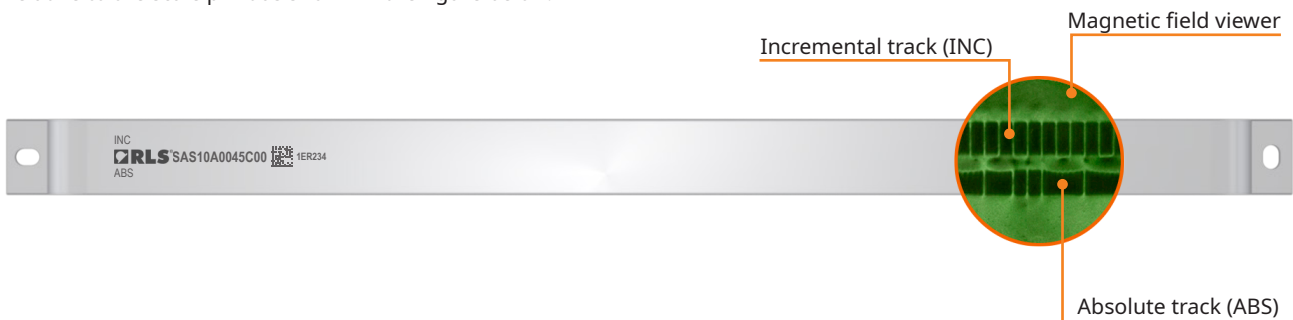

SAS10 scale surface print description

The print/engraving of the scale surface appears once per entire exposed/fully welded length of the scale. It includes the RLS logo, part number, serial number, marking of the incremental (INC) and absolute (ABS) track and QR code that contains serial number information.

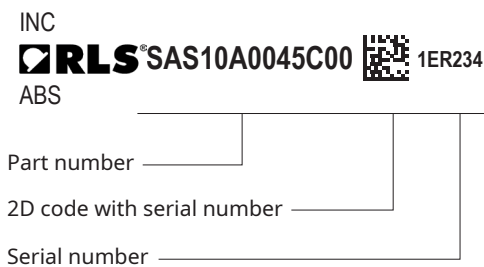

Technical specifications

System data	AS10	SAS10	DS19
Incremental pole length	2 mm	2 mm	2 mm
Maximum scale length	16.3 m	1.36 m (1.288 m measuring length)	2 m
Type of reading	Linear	Linear	Linear and partial arc (from OD 200 mm up)
Scale accuracy at 0.2 mm ride height*	±30 µm/m	±20 µm/m	±10 µm/m

*For more information about the accuracy please see the AST01 technical article at [RLS Media center](#).

Mechanical data

Material	Carrier	1.4310 stainless steel	1.4016 stainless steel	1.4310 stainless steel
	Magnetic medium	NBR elasto-ferrite	NBR elasto-ferrite	NBR elasto-ferrite
Thickness	Carrier	0.3 ±0.05 mm	-	0.3 ±0.05 mm
	Double-sided acrylic adhesive tape VHB 3M9469	0.13 mm	-	0.13 mm
	VHB liner thickness	0.1 mm	-	0.1 mm
	Cover foil	0.076 ±0.006 mm	-	0.076 ±0.006 mm
	Double sided tape	0.05 mm	-	0.05 mm
	Scale	1.43 ±0.1 mm (with back adhesive) 1.3 ±0.1 mm (without back adhesive)	6.08 ±0.03 mm	1.43 ±0.1 mm (with back adhesive) 1.3 ±0.1 mm (without back adhesive)
	Mass	62 g/m	700 g/m	93 g/m
Width	10 ^{-0.05} _{+0.15} mm	18 ±0.05 mm	15 ^{-0.05} _{+0.15} mm	
Cover foil width	CF10 (AS10) (for regular scale)	9.5 ±0.1 mm	-	-
	CF08 (AS10) (for track system)	7.6 ±0.35 mm	-	-
	CF15 (DS19)	-	-	14.5 ±0.35 mm
Length tolerance	±0.5 mm ±40 [µm/m] × 10 ⁻³ × scale length [m]	-	±0.5 mm ±15 [µm/m] × 10 ⁻³ × scale length [m]	
Expansion coefficient (carrier)	~17 × 10 ⁻⁶ [m/mK]	10.4 × 10 ⁻⁶ [m/mK]	~17 × 10 ⁻⁶ [m/mK]	

Environmental data

Temperature	Operating	-40 °C to +100 °C	-40 °C to +75 °C	-40 °C to +100 °C
	Storage	-40 °C to +60 °C	-40 °C to +75 °C	-40 °C to +60 °C

Installation instructions

Installation of AS10 and DS19 magnetic scale with adhesive tape

Installation surface preparation

Magnetic scales are equipped with VHB backside adhesive tape. Most substrates are best prepared by cleaning with a 50:50 mixture of isopropyl alcohol and water before applying the magnetic scale. Exceptions to the general procedure that may require additional surface preparation include:

- Heavy oil/grease: To remove heavy oil or grease from a surface, a degreaser or solvent-based cleaning agent may be required, followed by cleaning with IPA/water.
- Abrasion: Sanding a surface and then cleaning with IPA/water can remove heavy dirt or oxidation and improve adhesion.
- Adhesion promoters: Priming a surface can significantly improve initial and ultimate adhesion to many materials such as plastics and paints.
- Porous surfaces: Most porous and fibrous materials such as wood, chipboard, concrete, etc. must be sealed to provide a unified surface.
- Unique materials: Special surface preparation may be required for glass and glass-like materials, copper and copper-containing metals, plastics or rubber containing migrating components (e.g. plasticisers).

Further information can be found under "Surface Preparation for 3M™ VHB™ Tape Applications".

Scale application

To simplify the scale installation use the scale applicator tool LMA10ASC00 or ACC088. Mount the applicator tool to the readhead mounting bracket. Use two fasteners as per readhead mounting configuration. The same principle of installing the scale can be applied to the magnetic scale DS19 with a different tool (ACC088). Further details can be found on pages 12 to 14.

Fastener mounting variants

Variant A

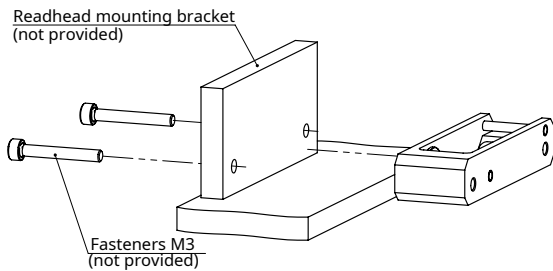

Variant B

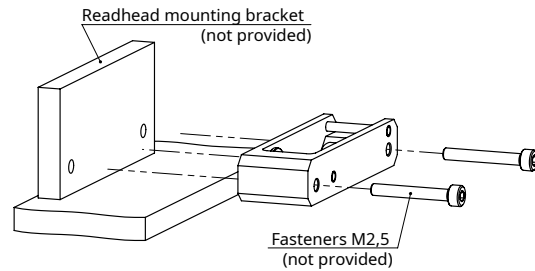

Good surface contact can be achieved by applying a pressure of about 100 kPa. At room temperature, approximately 50 % of the final bond strength is achieved after 20 minutes, 90 % after 24 hours and 100 % after 72 hours. Dynamic overlap shear (peak force to separate is measured after 72 hours dwell time): 830 kPa.

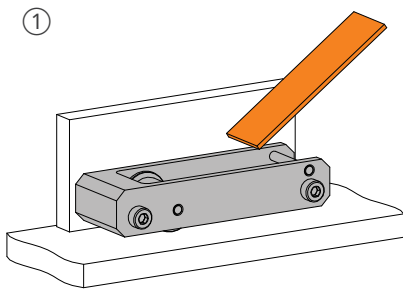

Load the scale into the applicator tool.

Separate the backing paper from the first 40 mm of scale and feed the scale into the applicator tool.

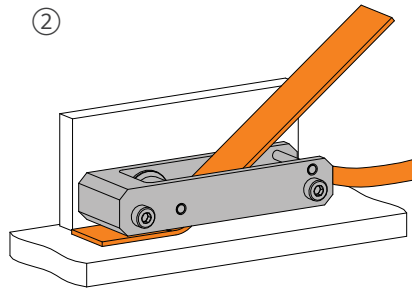

Apply the scale.

Push the scale carefully through to the end of scale mark, ensuring that it does not stick to the mounting surface until it is in position. Attach the end of the scale to the mounting surface with light finger pressure.

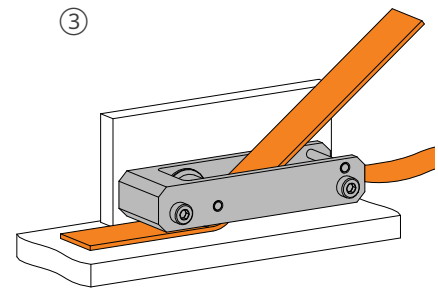

Ensure complete adhesion.

Apply firm finger pressure along the full length of the scale from the centre outwards to each end.

To prevent the scale from sticking to the mounting surface during this operation it may be necessary to re-apply approximately 20 mm of backing paper to the end of the scale before inserting through applicator tool.

Traverse the axis through its full travel at a slow, steady speed. While moving the axis apply a light pressure (with a finger) to the scale behind the applicator tool to attach it to the mounting surface and gently pull the backing paper away from the applicator tool as it is separated.

Installation of AS10 magnetic scale with end clamps

End clamp kit has been designed to anchor the ends of the AS10 magnetic scale. Make sure the installation surface is clean and free of debris. Included in the kit are 2 end clamps and 2 fasteners M2.5 × 6 DIN 965.

Installation process

All dimensions are in mm.

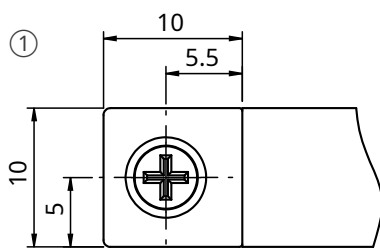

Prepare the mounting surface.

Drill the holes to the mounting surface as shown above.

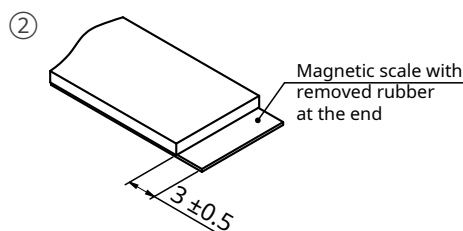

Prepare the magnetic scale.

If the scale was not ordered pre-prepared for installation with end clamps, please make sure that:

- the hole to hole distance is correct (Scale length + 6 mm),
- the rubber surface at the ends of the scale was cut and removed as shown in the figure above.

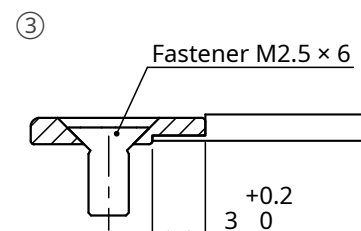

Install the scale to the surface.

Make sure that the scale has been cut to the correct length and the mounting surface has been cleaned. Install the self-adhesive scale using the scale applicator tool.

Install the end clamp.

Use the supplied fasteners and attach the end clamps so that the magnetic scale is held under the clamp.

Magnetic scales can be mounted only with the end clamp option, without additional use of VHB adhesive tape. However, in this case the mounting surface should be prepared for mounting. To prevent the magnetic scale from moving in the lateral axis, mill a 10 mm wide and >0.3 mm deep groove in the mounting surface.

If you mount the scale with end clamps only, without combining it with VHB, the recommended maximum length of the scale is 100 mm. End clamps are used to better fix the ends of the scale. We highly recommend to use both end clamps together with the VHB adhesive option.

Installation of AS10 magnetic scale with TRS

TRS system is designed for applications that require an easily removable scale. The track system consists of aluminium guide rails, available in 1 m and 2 m sections, and a scale clamp element. It holds the magnetic scale securely while allowing it to expand and contract freely. The scale clamp provides a fixed point from which the magnetic scale can expand.

If damaged, the scale can be pulled out of the guide rails and replaced even if access is limited, reducing machine downtime. This feature also makes the system ideal for large machines that need to be disassembled for transport.

The design of the track section allows installation next to most standard guide rails or freely on any surface. This makes it suitable for many applications, such as automated assembly lines, packaging equipment, printing and other machines where the scale must be installed/removed for transport, or simply for all applications where the thermal expansion of the scale must be independent of the machine structure.

TRS technical specifications

Material	Aluminium, EN AW-6060
Mass	157 g/m
Thermal expansion	~25 $\mu\text{m}/\text{m}/^\circ\text{C}$
Dimensions - cross section	20 mm \times 4 mm
Available section lengths	1 m, 2 m

Installation tips

Thermal expansion control

The scale can be fixed either at the left/right end or at the center depending on the thermal expansion scheme.

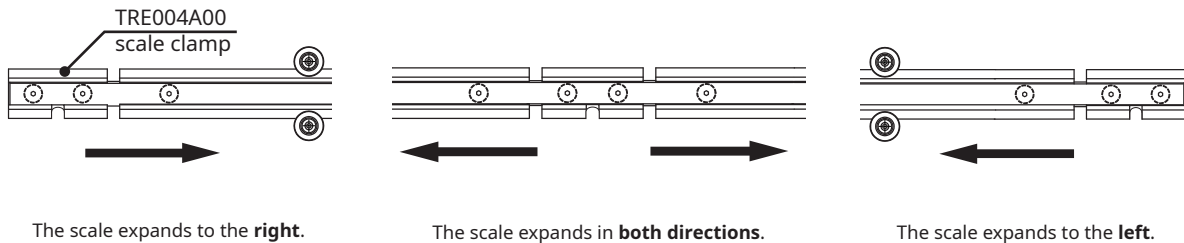

Alignment of different-level-substrate

The TRS system helps secure the level alignment of the scale across the whole axis.

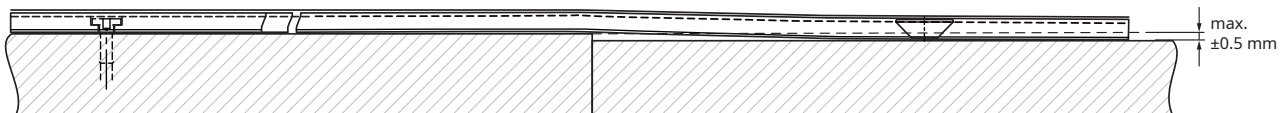

Installation methods

All dimensions are in mm.

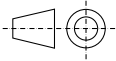

Installation method 1

Installation method 2

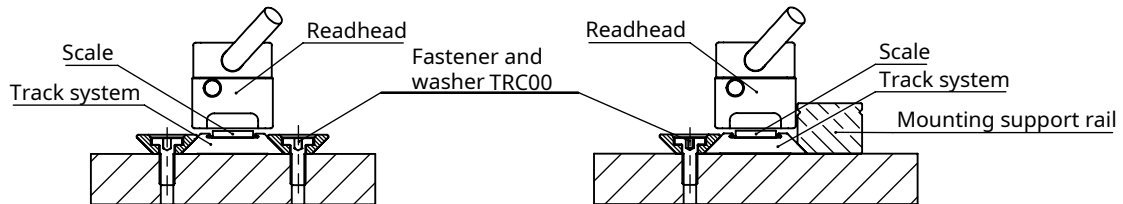

No mounting support rail available

Mounting support rail available for alignment of track section

Number of TRC00 (fasteners and washers) required

Track section	Installation method 1	Installation method 2
TRS100A00	8	4
TRS200A00	16	8

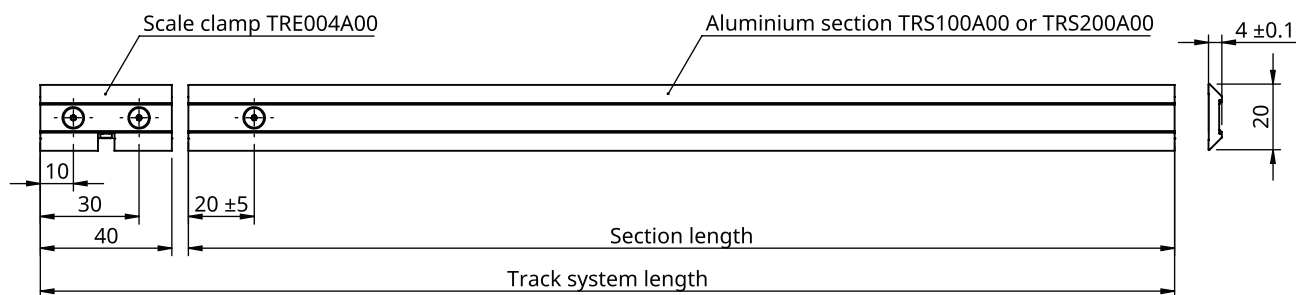

General tolerances: ISO 2768 m K

Installation method 1

All dimensions are in mm.

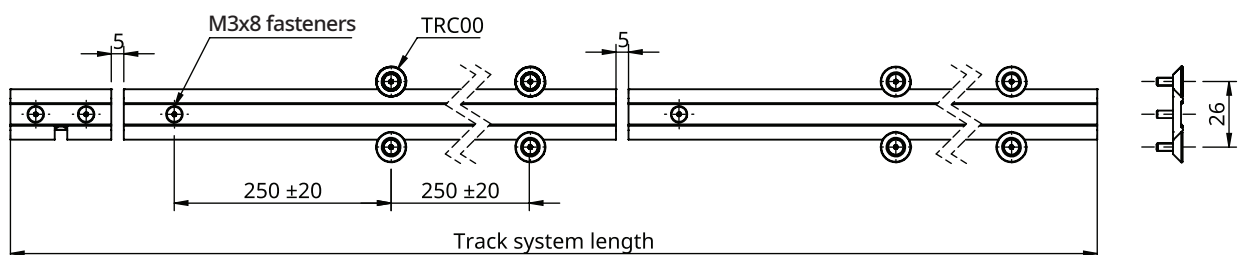
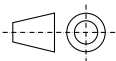

Installation method 2

All dimensions are in mm.

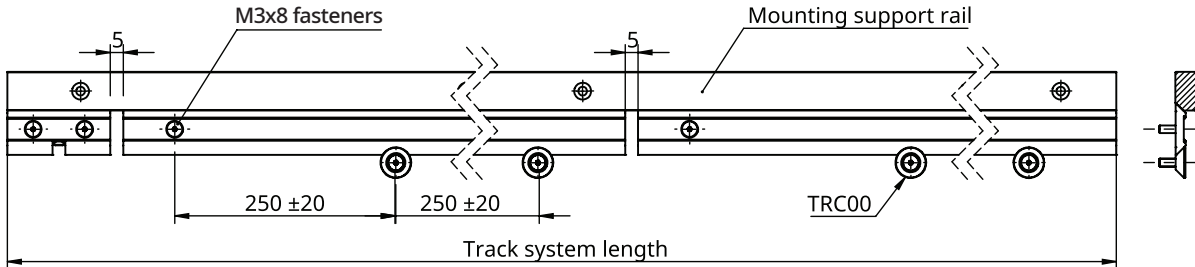
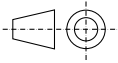

Recommended use of M3x 8 (CBSM3-8 Misumi). For more information see [Table of recommended fastener tightening torques](#) at [RLS Media center](#).

Installation of DS19 magnetic scale with adhesive and fasteners at both ends

The DS19 scale can be installed in 2 different ways:

- With adhesive tape only.
- With adhesive tape + fasteners at both ends.

The fasteners at both ends prevent the magnetic scale from peeling off the edges when installed on a curved surface (e.g. a rotating shaft). It is not recommended to install the scale just with the fasteners at both ends (without adhesive tape). Using just fasteners to attach the scale may not be sufficient and the scale may bend in the middle and come into contact with the readhead. This can lead to a malfunction.

The left side of the DS19 scale has a $\varnothing 3$ mm hole and a slot hole on the right side. The slot hole is used to compensate for the length tolerance of the scale and possibly also the tolerance between the holes on the shaft.

Before the final installation of the scale it is recommended to lay the scale over the shaft to see if the distance between the holes at both ends matches with the holes on the shaft.

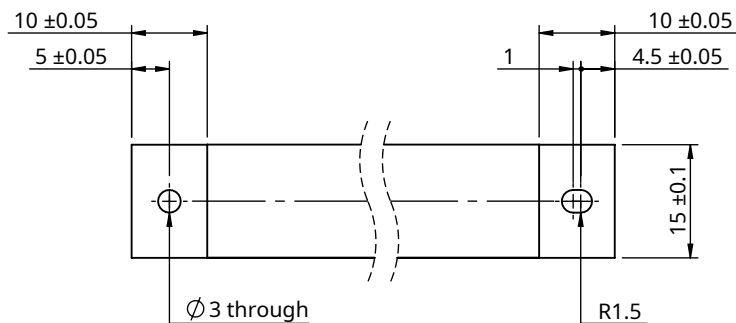

Installation of DS19 magnetic scale with installation tool (ACC088)

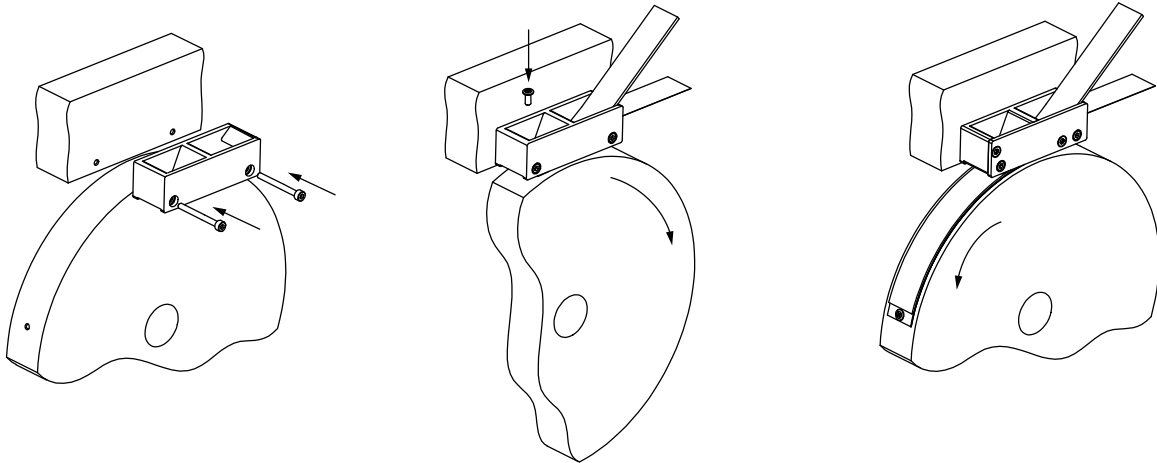

- ① Install the applicator for DS19 scale.
- ② Place the magnetic scale into the right opening and peel off the 40 mm of the liner that protects the adhesive. Lead the liner through the bottom right opening.
- ③ Push the scale carefully through to the end while rotating the shaft.
- Align the hole in the shaft with the hole in the scale. Insert the supplied fastener (ARC00) through the top hole of the installation tool and attach the left end of the scale. Use the recommended torque from the **Table of recommended fastener tightening torques**.

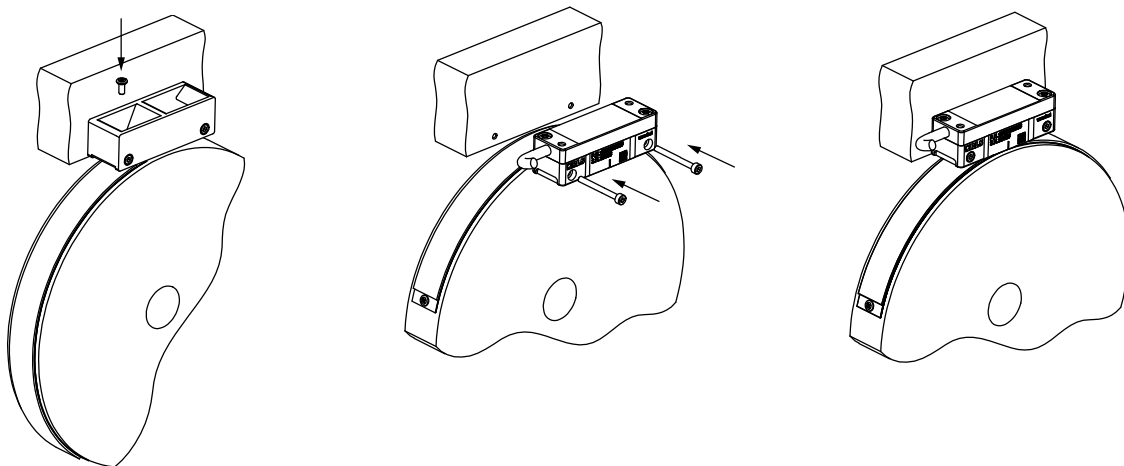

- ④ Insert the supplied fastener (ARC00) through the top hole of the installation tool and attach the right end of the scale. Use the recommended torque from the **Table of recommended fastener tightening torques**.
- ⑤ Install the readhead.
- ⑥ Align the readhead according to the tolerance specification (radial, axial, tangential offsets). A simple 0.3 mm thick plastic shim can be used to set up the air gap between the scale and the readhead.

If the shaft's range of motion is limited and the scale cannot be fully installed, the installation tool must be removed from the base bracket and carefully taken off the scale.

Apply firm finger pressure over the entire length of the scale.

Installation of DS19 magnetic scale on the shaft with the installation lip

Design the shaft with the installation lip >0.3 mm high. The installation lip must be laterally (axially) correctly positioned to align the scale based on the tolerance specification of the readhead. The installation lip will lead the magnetic scale in a straight line during installation.

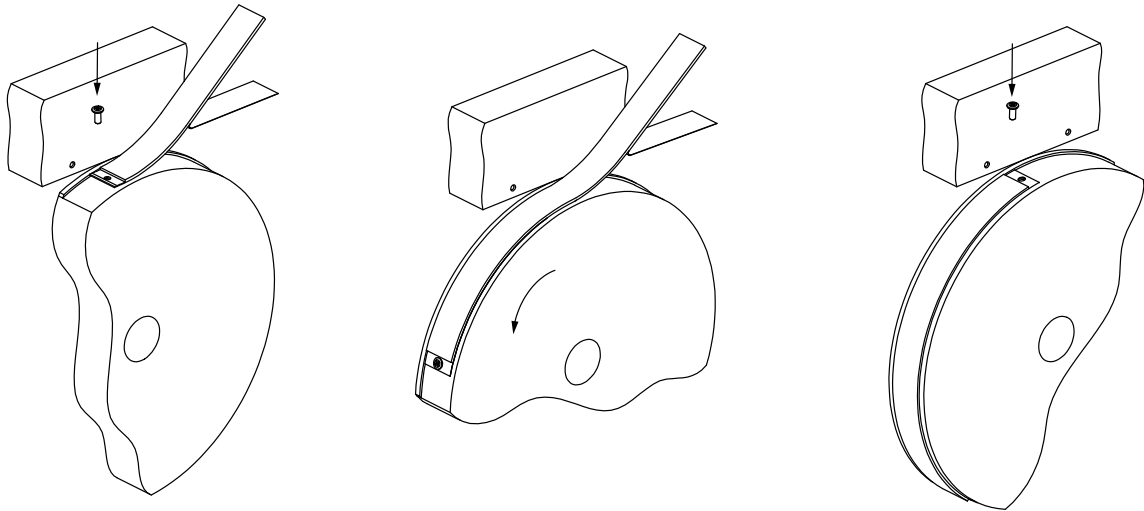

① Peel of the first 20 mm of liner that protects the adhesive from magnetic scale.

Align the hole of the shaft with the hole on the scale. Fasten down the left end of the scale with included fastener (ARC00). Use the recommended torque from the **Table of recommended fastener tightening torques.**

② Apply the scale alongside the installation lip while slowly rotating the shaft and peeling off the liner.

③ Use the included fastener (ARC00) and fasten down the right side of the scale. Use the recommended torque from the **Table of recommended fastener tightening torques.**

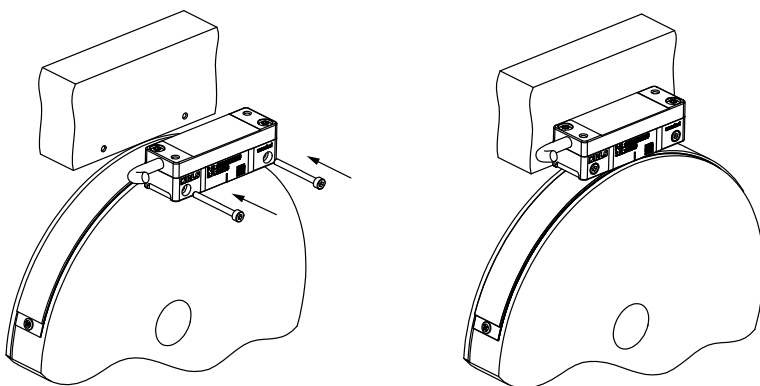

④ Install the readhead.

⑤ Align the readhead according to the tolerance specification (radial, axial, tangential offsets). A simple 0.3 mm thick plastic shim can be used to set up the air gap between the scale and the readhead.

Installation of solid absolute scale (SAS10)

All dimensions are in mm.

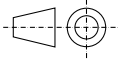

Mounting on steel substrate with similar coefficient of thermal expansion (CTE) - recommended. Make sure that the mounting surface of the magnetic scale has been cleaned and degreased before you proceed.

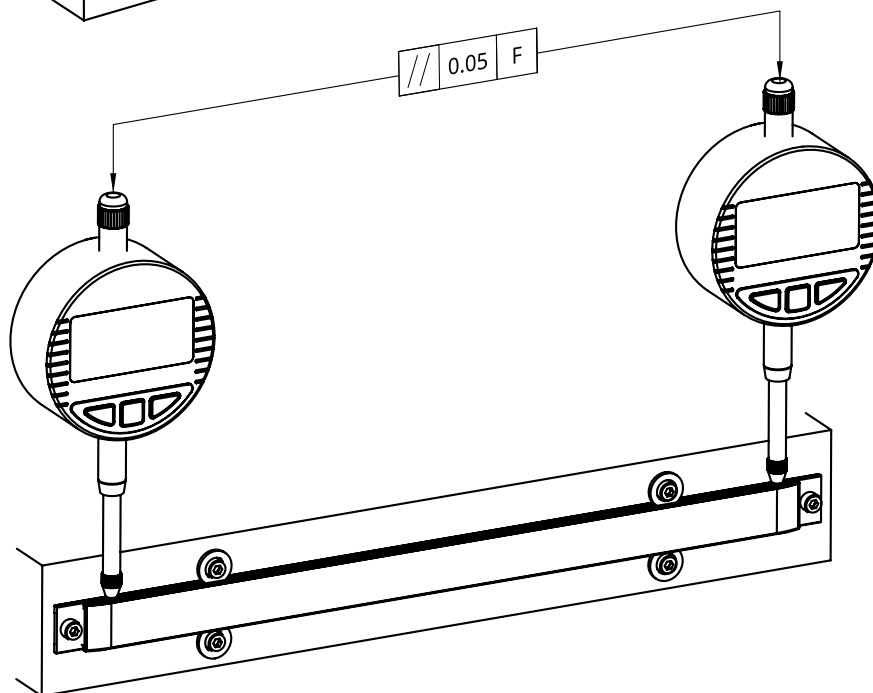
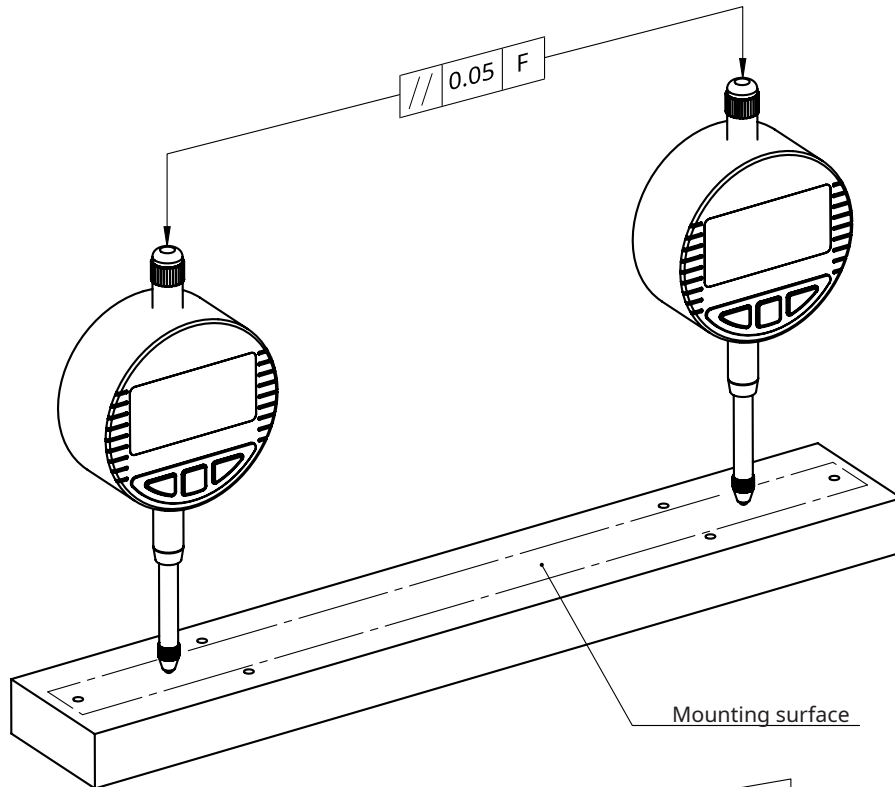

F: Machine guideway

To achieve specified performance, maintain the mounting surface and the readhead guideway inside 0.05 mm parallelism according to the machine guideway.

For scales up to 150 mm long:

Mount the left-most and right-most fasteners with a force of 1.2 Nm (no washers required).

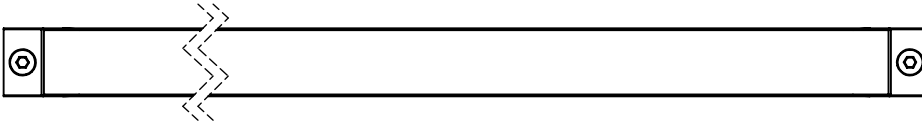

For scales longer than 150 mm:

Use washers every 150 mm along the scale to prevent bending. Mount the left-most and rightmost fasteners with force of 1.2 Nm. A required number of fasteners and washers is supplied with the scale.

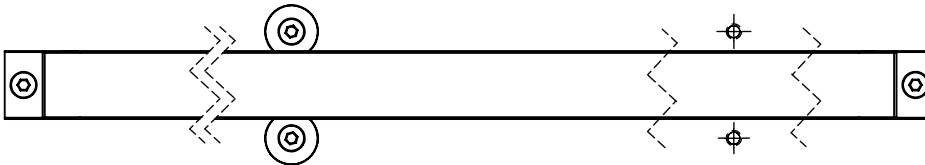

Example of SAS10 scale mounting (top view):

Dimensions and tolerances are in mm.

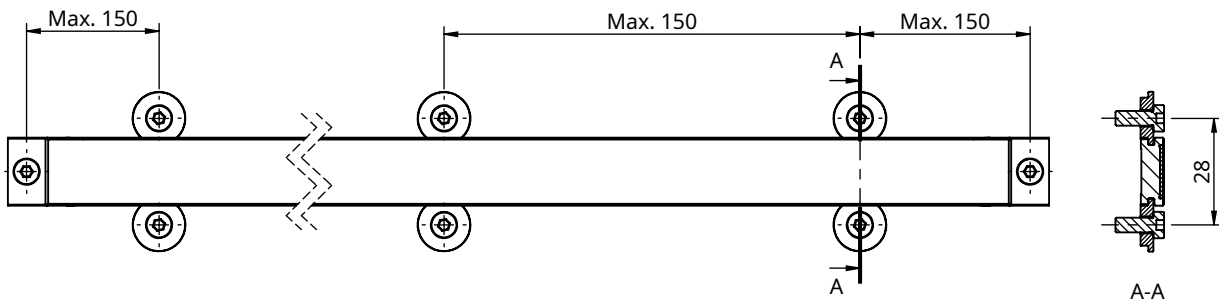

Installation tolerances

Ride height (RH) for linear application of the scales

Values in the table apply when the scale is installed on the flat surface (the scale is not curved).



		RH for LA11/LA12		RH for LF11	RH for ARTOS™
		AS10	SAS10	AS10	DS19
No cover foil	With or without adhesion tape	0.1 to 0.6	0.1 to 0.5	0.1 to 0.7	0.1 to 1.0
	Scale prepared for track system	0.1 to 0.5	/	0.1 to 0.6	/
With cover foil	With or without adhesion tape	0.1 to 0.5	0.1 to 0.5	0.1 to 0.6	0.1 to 0.9
	Scale prepared for track system	0.1 to 0.4	/	0.1 to 0.5	/

Values in mm.

The optimal installation is at 0.2 mm ride height. For easier and more reliable installation please use a 0.2 mm thick shim.

AS10 with LA11/LA12/LF11

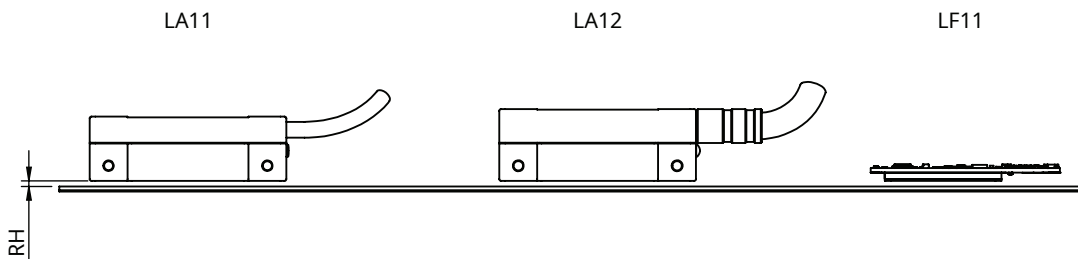

DS19 with Artos™

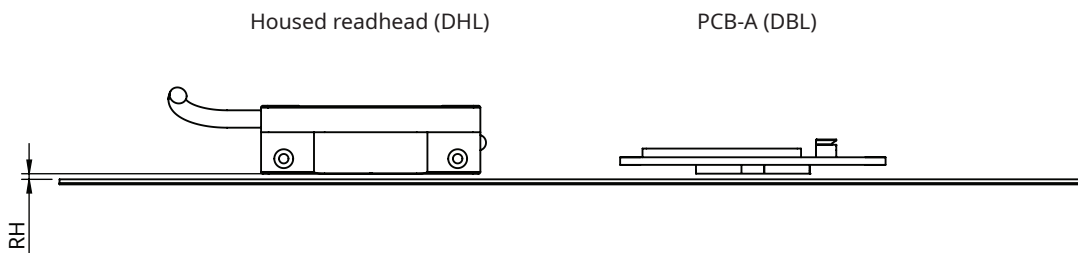

SAS10 with LA11/LA12

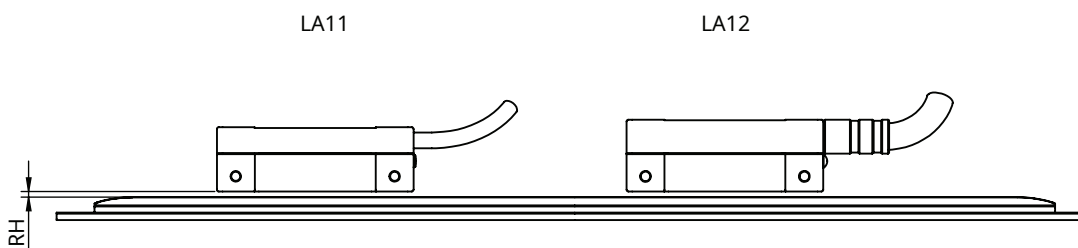

Ride height (RH) and center line offset for partial arc application of the DS19 scales

Values in the table below apply when the scale is installed on a curved surface (only applicable for DS19 scale). Minimum bending radius is 100 mm.

Housed readhead

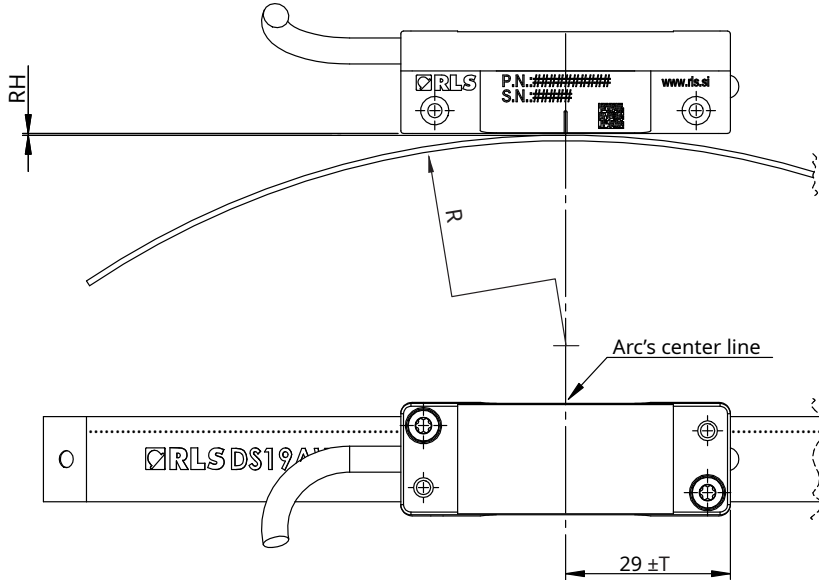

PCB-A readhead

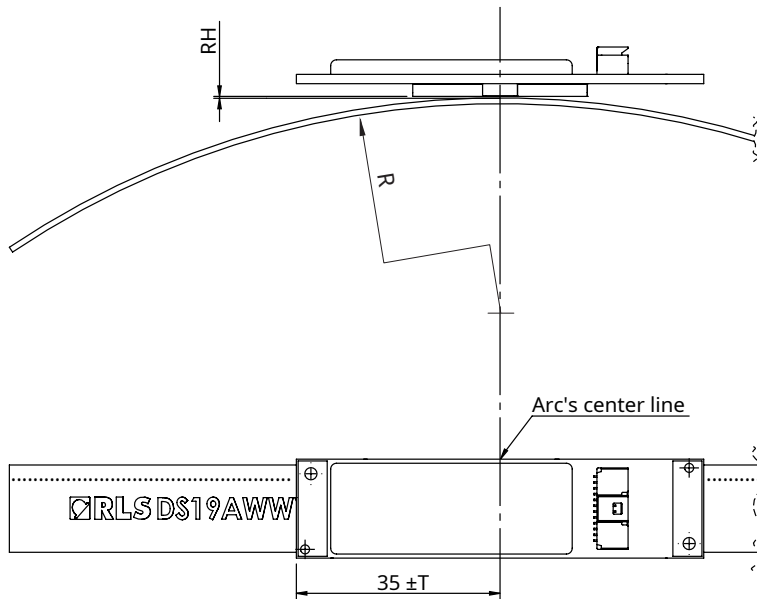

Scale PN	Shaft OD	Ride height (RH)	Tangential (T) / center line offset
No cover foil	200 - 249 mm	0.1 to 0.7 mm	1 mm
	250 - 299 mm	0.1 to 0.85 mm	
	300 mm and up	0.1 to 1.0 mm	
With cover foil	200 - 249 mm	0.1 to 0.6 mm	
	250 - 299 mm	0.1 to 0.75 mm	
	300 mm and up	0.1 to 0.9 mm	

Lateral offset (LO)



		LA11/LA12		LF11	ARTOS™ DHL	ARTOS™ DBL
		AS10	SAS10	AS10	DS19	
No cover foil	With or without adhesion tape	3 ±0.3	±0.2	1 ±0.3	2.5 ±1 mm	1 ±1 mm
	Scale prepared for track system	3 ±0.2		1 ±0.2	/	/
With cover foil	With or without adhesion tape	3 ±0.3		1 ±0.3	2.5 ±1 mm	1 ±1 mm
	Scale prepared for track system	3 ±0.2		1 ±0.2	/	/

Values in mm.

AS10 with LA11/LA12/LF11

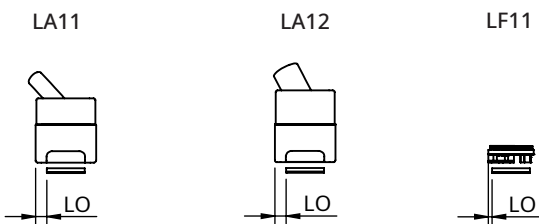

SAS10 with LA11/LA12

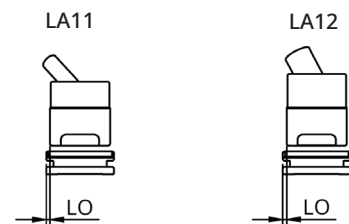

DS19 with Artos™

Housed readhead (DHL)

PCB-A (DBL)

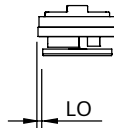
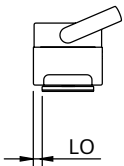

Roll, pitch and yaw

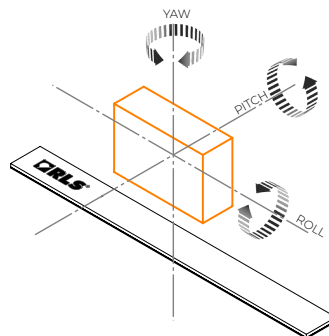

	RH for LA11/LA12		RH for LF11	RH for ARTOS™
	AS10	SAS10	AS10	DS19
Non-parallel mounting (roll)	±1°	±1°	±1°	±1°
Non-parallel mounting (yaw)	±0.5°	±0.5°	±0.5°	±1°
Non-parallel mounting (pitch)	±0.5°	±0.5°	±0.5°	±1°

Maximum speed tables

LA11 (parallel incremental signals)

AS10, SAS10

Ordering code	Resolution (µm)	Interpolation factor	Maximum speed (m/s)								
			1.82	0.91	0.23	0.11	0.06	0.03	0.02	0.01	0.01
13B	~0.244	8,192	1.82	0.91	0.23	0.11	0.06	0.03	0.02	0.01	0.01
12B	~0.488	4,096	3.65	1.82	0.46	0.23	0.12	0.06	0.05	0.02	0.01
11B	~0.976	2,048	7	3.65	0.91	0.46	0.24	0.12	0.10	0.05	0.02
2D0	1	2,000	7	3.73	0.93	0.47	0.24	0.12	0.10	0.05	0.02
10B	~1.953	1,024	7	7	1.82	0.91	0.48	0.24	0.19	0.10	0.05
09B	~3.906	512	7	7	3.65	1.82	0.95	0.49	0.38	0.19	0.10
08B	~7.812	256	7	7	7	3.65	1.90	0.97	0.77	0.39	0.19
07B	15.625	128	7	7	7	7	3.81	1.94	1.53	0.77	0.39
06B	31.25	64	7	7	7	7	7	3.89	3.07	1.55	0.78
05B	62.5	32	7	7	7	7	7	7	6.14	3.10	1.56
04B	125	16	7	7	7	7	7	7	7	6.19	3.11
Minimum edge separation (µs)			0.07	0.12	0.50	1	2	4	5	10	20
Maximum count frequency (MHz)			15	8	2	1	0.50	0.25	0.20	0.10	0.05
Part numbering			K	A	B	C	D	E	F	G	H

LA12

AS10, SAS10

Ordering code	Resolution (µm)	Interpolation factor	Maximum speed (m/s)
13B	~0.244	8,192	2
12B	~0.488	4,096	4
11B	~0.976	2,048	7
8D0	0.250	8,000	2
2D0	1	2,000	7
1D0	2	1,000	7

LF11

AS10

Ordering code	Resolution (µm)	Interpolation factor	Maximum speed (m/s)
13B	~0.244	8,192	1.85
12B	~0.488	4,096	3.65
11B	~0.976	2,048	7

Artos

DS19

The maximum linear speed is 20 m/s regardless of the chosen resolution on DHL and DBL readheads. Refer to [Maximum speed calculator for scales](#).

How to define scale length

AS10 installation with LA11 and LA12 readhead

1 and 2 are encoder position limits

If special requirement AS10_03 (03 - absolute code begins with zero) is selected and the readhead is at location 1 as shown on the drawing below, the readhead reports the absolute position 5 ± 1 mm.

The absolute position reported by the encoder at location 2 can be calculated with the following equation:

Absolute position value 2 = $x - 27$ mm (within tolerance ± 1 mm)

x = Total length of the effective part of the magnetic scale (elasto-ferrite rubber)

Installation of AS10 magnetic scale with adhesive tape

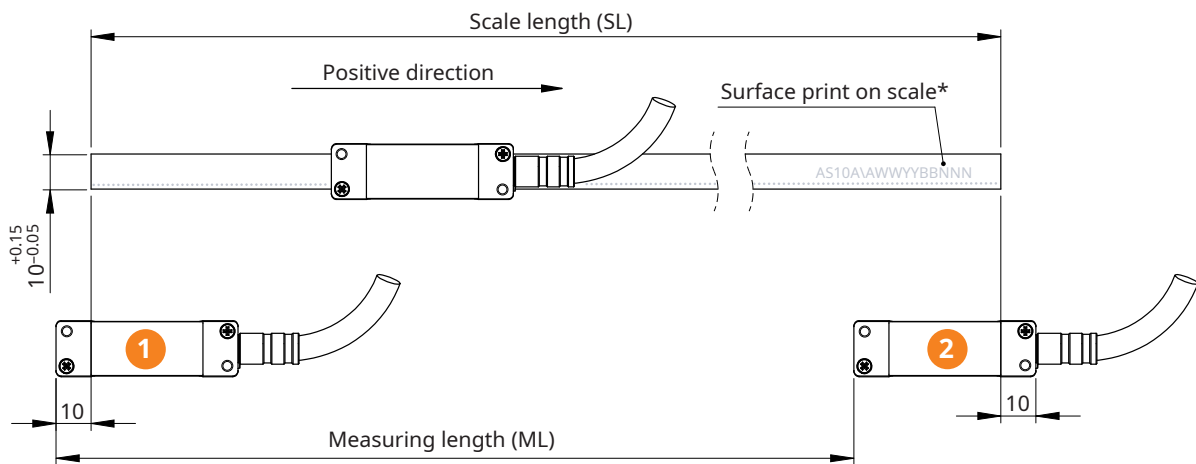

$$ML = SL - 32 \text{ mm}$$

* Scale surface print does not represent the actual ordering code. For orientation purpose only.

Installation of AS10 magnetic scale with end clamps

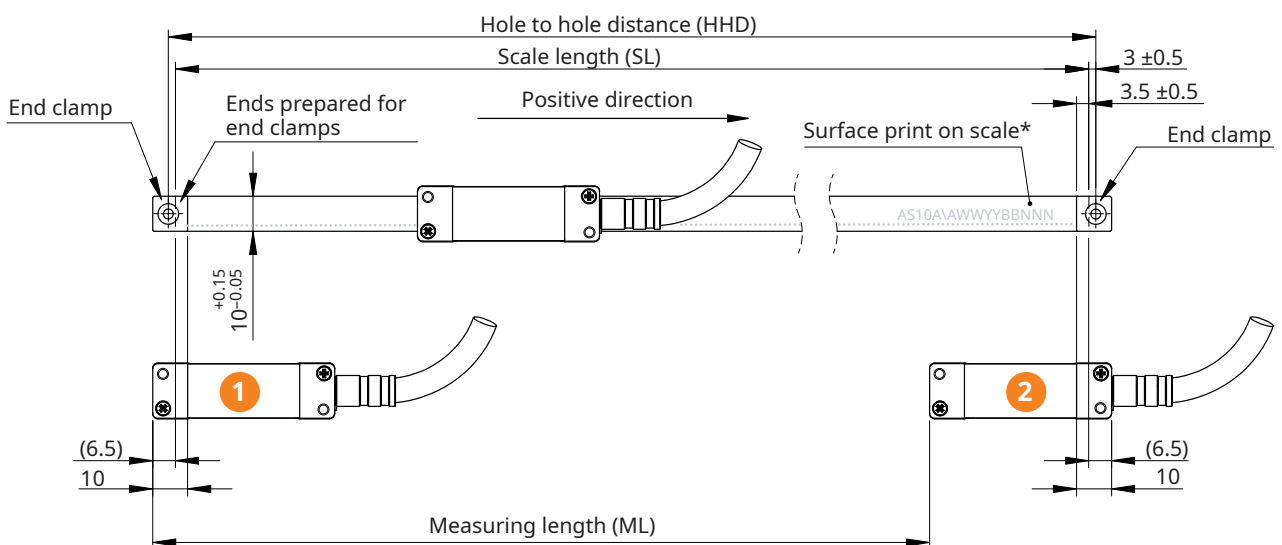

$$ML = SL - 39 \text{ mm}$$

$$HHD = SL + (6 \text{ mm} \pm 1 \text{ mm})$$

* Scale surface print does not represent the actual ordering code. For orientation purpose only.

SAS10 installation with LA11 and LA12 readhead

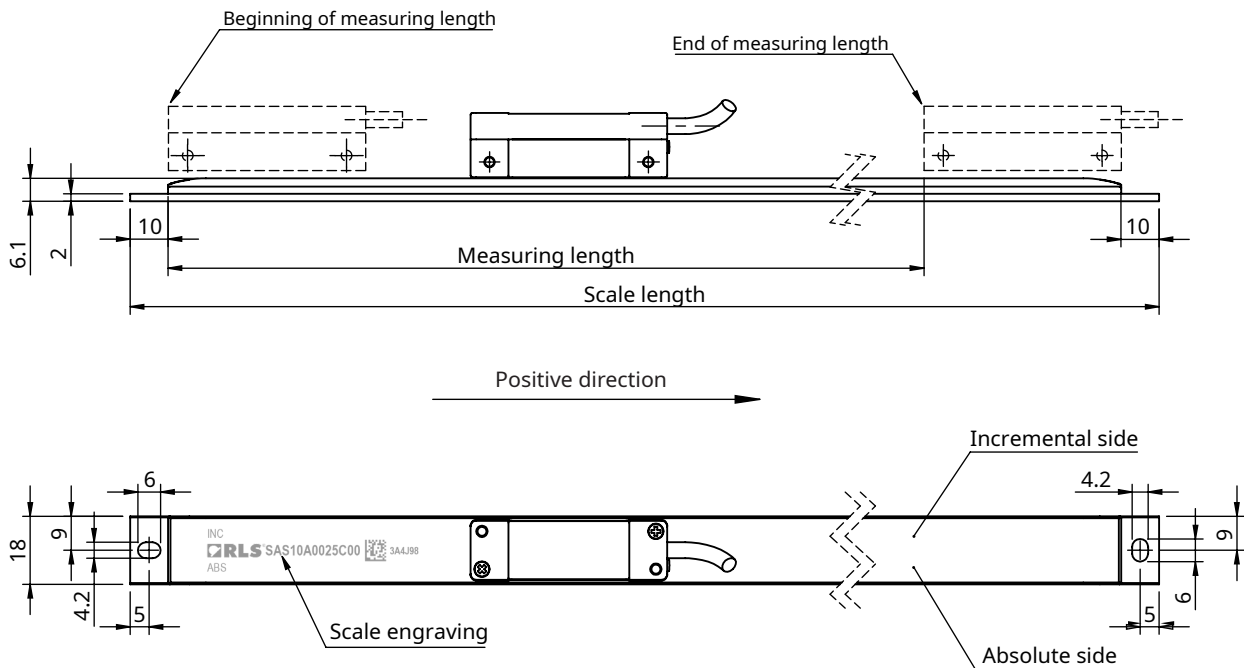

$$ML = SL - 72 \text{ mm}$$

SAS10 scales always start with the absolute position 0 regardless of scale length.

Scale length [mm]	Measuring length (LA11/LA12) [mm]	Nr. of washer (MN01509)	Nr. of fasteners (M4 x 10 IMBUS ISO 7380)*
97	25	2	4
117	45	2	4
162	90	2	4
192	120	2	4
272	200	2	4
322	250	4	6
372	300	4	6
472	400	6	8
560	488	6	8
660	588	8	10
760	688	10	12
860	788	10	12
960	888	12	14
1060	988	14	16
1160	1088	14	16
1260	1188	16	18
1360	1288	18	20

* 2 additional screws to attach the scale at both ends. 2 standard washers M4 DIN 125 stainless-steel included.

AS10 installation with LF11 readhead

① and ② are encoder position limits

If special requirement 03 (absolute code begins with zero) is selected and the readhead is at location ① as shown on the drawing below, the readhead reports the absolute position 3 ± 1 mm.

The absolute position reported by the encoder at location ② can be calculated with the following equation:

Absolute position value ② = $x - 30$ mm (within tolerance ± 1 mm)

x = Total length of the effective part of the magnetic scale (elasto-ferrite rubber)

Installation of AS10 magnetic scale with adhesive tape

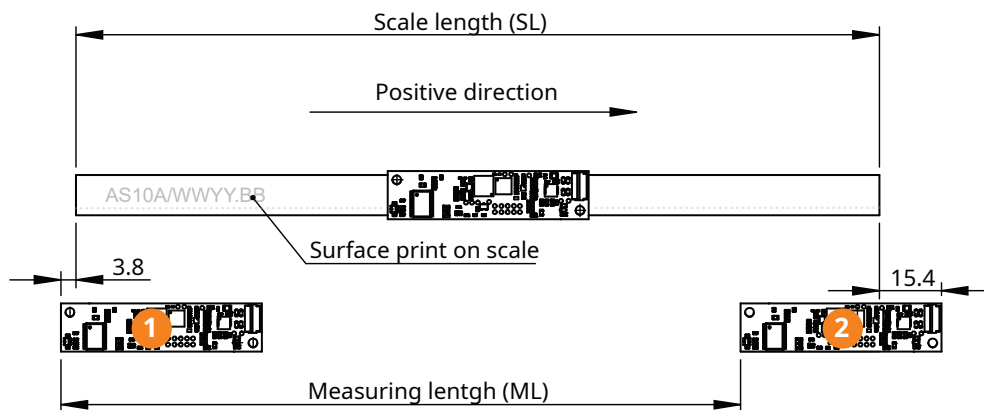

$$ML = SL - 31 \text{ mm}$$

* Scale surface print does not represent the actual ordering code.
For orientation purpose only.

Installation of AS10 magnetic scale with end clamps

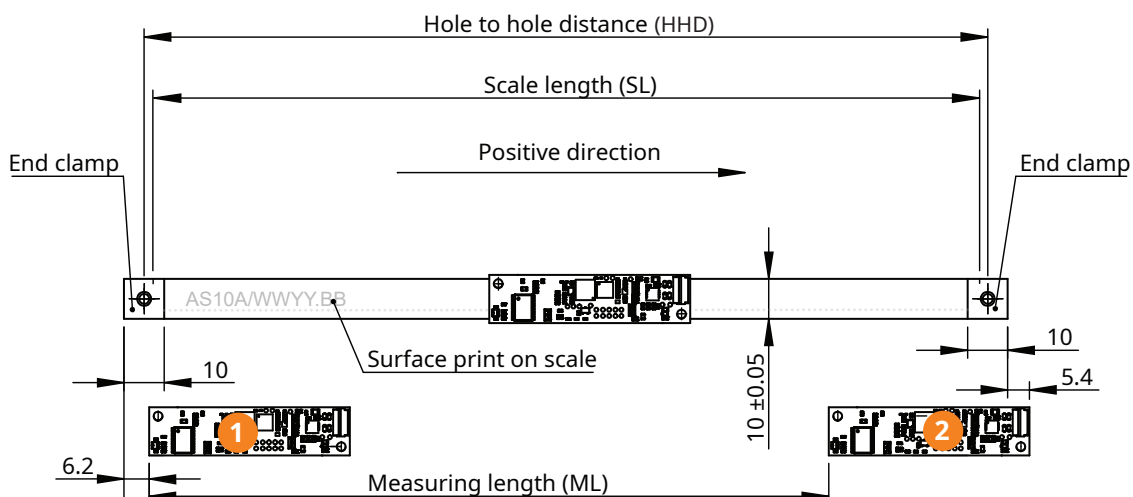

$$ML = SL - 38 \text{ mm}$$

$$HHD = SL + (6 \text{ mm} \pm 1 \text{ mm})$$

$$SL \text{ tolerance} = \pm(0.5 \text{ mm} + 0.04 \text{ mm/m})$$

* Scale surface print does not represent the actual ordering code.
For orientation purpose only.

DS19 installation with Artos™ enclosed readhead

① and ② are encoder position limits

If the **absolute code type "Z"** (absolute code begins with zero) is selected and the readhead is at location ① as shown on the drawing below, the readhead reports the absolute position 11 ± 1 mm.

The absolute position reported by the encoder at location ② can be calculated with the following equation:

$ML = SL - n$, stated under corresponding DS19 scale type.

Installation of DS19 magnetic scale

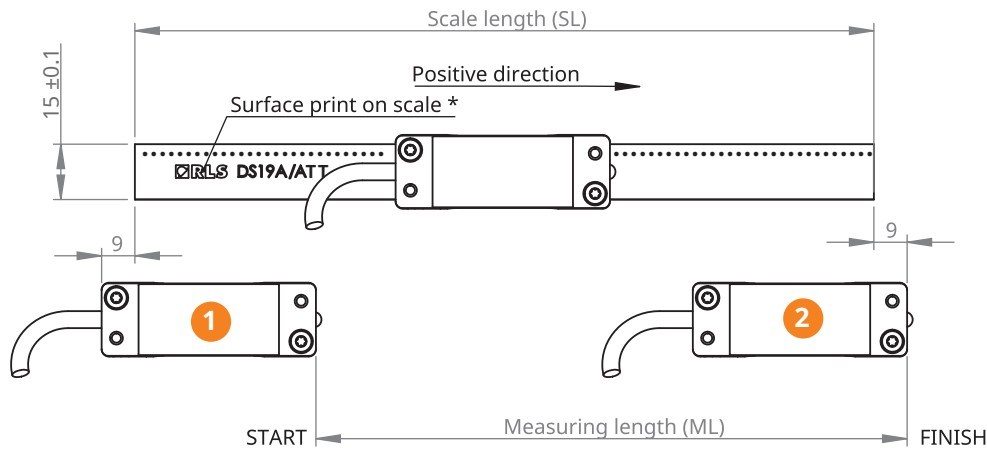

$ML = SL - 40$ mm
 $HHD = SL - 10$ mm
 SL tolerance = $\pm(0.5$ mm + 0.02 mm/m)

* Scale surface print does not represent the actual ordering code.
 For orientation purpose only.

Installation of DS19 magnetic scale with fasteners at both ends of the scale

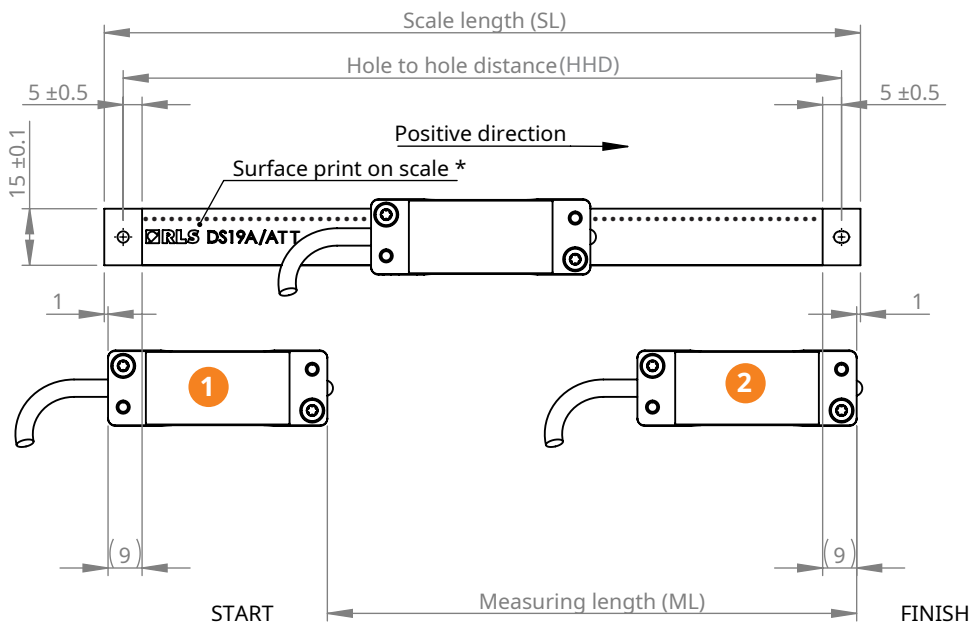

$ML = SL - 60$ mm
 $HHD = SL - 10$ mm
 SL tolerance = $\pm(0.5$ mm + 0.02 mm/m)

* Scale surface print does not represent the actual ordering code.
 For orientation purpose only.

DS19 installation with Artos™ PCB-A readhead

① and ② are encoder position limits

If the **absolute code type "Z"** (absolute code begins with zero) is selected and the readhead is at location ① as shown on the drawing below, the readhead reports the absolute position 11 ± 1 mm.

The absolute position reported by the encoder at location ② can be calculated with the following equation:

$ML = SL - n$, stated under corresponding DS19 scale type.

Installation of DS19 magnetic scale

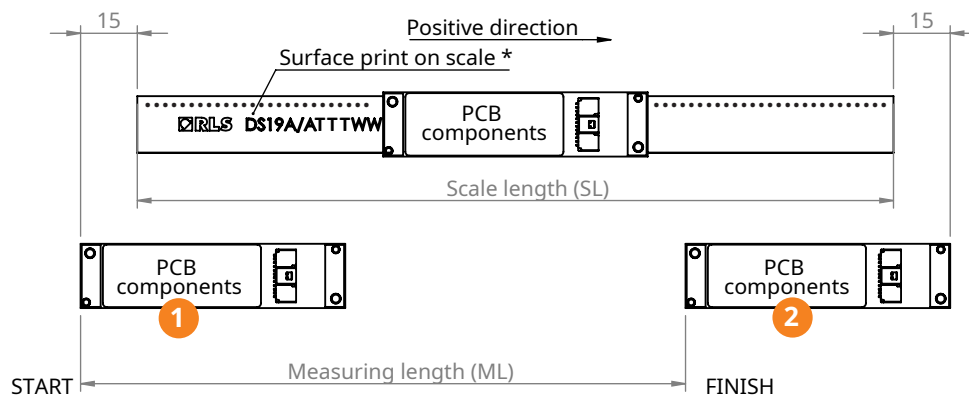

* Scale surface print does not represent the actual ordering code.
For orientation purpose only.

$ML = SL - 40$ mm
 $HHD = SL - 10$ mm

Installation of DS19 magnetic scale with fasteners at both ends of the scale

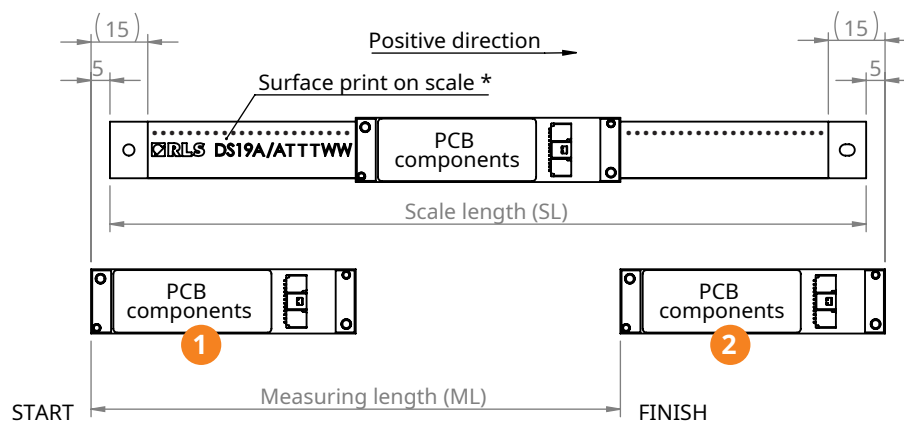

* Scale surface print does not represent the actual ordering code.
For orientation purpose only.

$ML = SL - 60$ mm
 $HHD = SL - 10$ mm

Part numbering

AS10

AS 10 A 01000 A 00

Accuracy class

A - N/A

Scale length

xxxxx - Where xxxxx equals scale length in mm

Options

- A - VHB back adhesive tape (standard)
- B - VHB back adhesive tape; with cover foil *
- C - VHB back adhesive tape; ends prepared for end clamping
- G - No VHB back adhesive tape; sides prepared for insertion into track section
- H - No VHB back adhesive tape, sides prepared for insertion into track section; with cover foil *
- I - No back adhesive tape
- N - No back adhesive tape; with cover foil *
- P - No back adhesive tape; ends prepared for end clamping **

* Cover foil is not factory mounted on the scale and must be ordered separately.

** It can only be used when the magnetic scale is installed in the groove to prevent lateral sliding.

The groove dimension must correspond to the scale width.

Special requirements

- 00 - No special requirements (standard)
- 03 - Absolute code begins with 0. Available up to 16.3 m

The AS10 magnetic scale without the special option («00») is randomly cut from a reel with the corresponding absolute position of the 16.3 m long scale.

Table of available combinations

Series	Accuracy class	Scale length	Options	Reference mark
AS10	A	xxxx	A / B / C / G / H / I / N / P	00 / 03

SAS10

SAS10 A 1100 A 00

Requirement

A - N/A

Measuring scale length (max. 1288 mm)

0025 - 25 mm	0250 - 250 mm	0688 - 688 mm	1188 - 1188 mm
0045 - 45 mm	0300 - 300 mm	0788 - 788 mm	1288 - 1288 mm
0090 - 90 mm	0400 - 400 mm	0888 - 888 mm	
0120 - 120 mm	0488 - 488 mm	0988 - 988 mm	
0200 - 200 mm	0588 - 588 mm	1088 - 1088 mm	

For longer scale options (>1.3m) please [contact RLS](#).

Options

A - No cover foil
C - Welded cover foil

Special requirement

00 - N/A (no special requirement)

Table of available combinations

Series	N/A	Measuring scale length	Options	Special requirement
SAS10	A	xxxx	A / C	00

DS19

DS 19 001 A 01000 Z L A S A 00

Absolute scale family

DS - Absolute scale Artos (linear and partial arc)

Scale width

19 - Width 15 mm, 2 mm pole pitch

Scale type

001 - Linear and partial arc magnetic scale **DS19**
(up to 2 m long scale, minimum bending diameter 200 mm)

N/A

A - N/A

Scale length

xxxxx - Where xxxxx equals length in mm

Max 2 m long (PN = 02000)

Absolute code type

R - Random cut of the scale with a random start of the absolute code
Z - Start with absolute zero

Mechanical option

A - Without holes
L - With holes at both ends of the scale (fasteners included)

Option - adhesive

A - With VHB 3M adhesive tape
B - Without VHB 3M adhesive tape

N/A

S - N/A

Packaging type

A - Box (individual packaging above 330 mm length)
C - Tube (individual packaging up to 330 mm length)

Special requirements

00 - No special requirements

The DS19 magnetic scale with an absolute code type "R" is randomly cut from a reel with the corresponding absolute position of the 2 m long scale.

Table of available combinations DS19

Scale family	Partial arc	N/A	Scale length*	Absolute code	Mechanical option	Options - adhesive	N/A	Packaging type	Special requirements
DS19	001	A	xxxxx	R / Z	A / L	A / B	S	A / C	00

* Up to 2 m long scale (02000 PN).

Cover foil part numbering

CF 10 1000

Cover foil width

- 08 - 08 mm width (for AS10 track system option only)
- 10 - 10 mm width (for AS10 scale)
- 15 - 15 mm width (for DS19 scale)

Cover foil length

xxxx - Where xxxx equals foil length in cm

Accessories



Magnet viewer
MM0001



End clamp kit
LM10ECL00

(2 clamps + 2 fasteners)



Track section, 1.00 m
TRS100A00

(1x fastener M3x10 included)



Applicator tool for magnetic
scale and cover foil
LMA10ASC00



Fastener and washer for TRS
profile
TRC00



Track section, 2.00 m
TRS200A00

(1x fastener M3x10 included)



Scale clamp with fasteners,
0.04 m
TRE004A00

(2x fastener M3x10 and 1x fastener
M2x4 included)



Washer for SAS10
MN01509

(included when ordering the
SAS10 scale)



Installation tool for DS19
ACC088

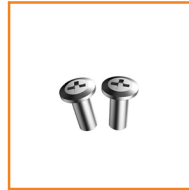

Fastener for DS19 partial arc
ARC00

Head office

RLS Merilna tehnika d. o. o.

Poslovna cona Žeje pri Komendi
Pod vrbami 2
SI-1218 Komenda
Slovenia

T +386 1 5272100
E mail@rls.si
www.rls.si

Global support

Visit our [website](#) to contact your nearest sales representative.

Document issues

Issue	Date	Page	Description
4	19. 3. 2024	-	DS19 option added
5	21. 6. 2024	28	Part numbering amended
6	11. 7. 2024	5, 6	DS19 print amended
7	20. 8. 2024	22	Number of washer and fastener added
		23	Installation of AS10 with end clamps drawing amended
8	5. 11. 2024	29	Part numbering amended

This product is not designed or intended for use outside the environmental limitations and operating parameters expressly stated on the product's datasheet. Products are not designed or intended for use in medical, military, aerospace, automotive or oil & gas applications or any safety-critical applications where a failure of the product could cause severe environmental or property damage, personal injury or death. Any use in such applications must be specifically agreed to by seller in writing, and is subject to such additional terms as the seller may impose in its sole discretion. Use of products in such applications is at buyer's own risk, and buyer will indemnify and hold harmless seller and its affiliates against any liability, loss, damage or expense arising from such use. Information contained in this datasheet was derived from product testing under controlled laboratory conditions and data reported thereon is subject to the stated tolerances and variations, or if none are stated, then to tolerances and variations consistent with usual trade practices and testing methods. The product's performance outside of laboratory conditions, including when one or more operating parameters is at its maximum range, may not conform to the product's datasheet. Further, information in the product's datasheet does not reflect the performance of the product in any application, end-use or operating environment buyer or its customer may put the product to. Seller and its affiliates make no recommendation, warranty or representation as to the suitability of the product for buyer's application, use, end-product, process or combination with any other product or as to any results buyer or its customer might obtain in their use of the product. Buyer should use its own knowledge, judgment, expertise and testing in selecting the product for buyer's application, end-use and/or operating environment, and should not rely on any oral or written statement, representation, or samples made by seller or its affiliates for any purpose. EXCEPT FOR THE WARRANTIES EXPRESSLY SET FORTH IN THE SELLER'S TERMS AND CONDITIONS OF SALE, SELLER MAKES NO WARRANTY EXPRESS OR IMPLIED WITH RESPECT TO THE PRODUCT, INCLUDING ANY WARRANTY OF MERCHANTABILITY OR FITNESS FOR ANY PARTICULAR PURPOSE, WHICH ARE DISCLAIMED AND EXCLUDED. All sales are subject to seller's exclusive terms and conditions of sale which, where the seller is (a) RLS Merilna tehnika d. o. o., are available at <https://www.rls.si/eng/salesterms>, (b) Renishaw, Inc., are available at <https://www.renishaw.com/legal/en/-/42186>, or (c) another person, are available on request, and in each case, are incorporated herein by reference, and are the exclusive terms of sale. No other terms and conditions apply. Buyer is not authorized to make any statements or representations that expand upon or extend the environmental limitations and operating parameters of the products, or which imply permitted usage outside of that expressly stated on the datasheet or agreed to in writing by seller.

RLS Merilna tehnika d. o. o. has made considerable effort to ensure the content of this document is correct at the date of publication but makes no warranties or representations regarding the content. RLS Merilna tehnika d. o. o. excludes liability, howsoever arising, for any inaccuracies in this document. © 2024 RLS d. o. o.